

IGLOO nano Low-Power Flash FPGAs with Flash*Freeze Technology



Features and Benefits

Low Power

- nanoPower Consumption—Industry's Lowest Power
- 1.2 V to 1.5 V Core Voltage Support for Low Power
- Supports Single-Voltage System Operation
- Low-Power Active FPGA Operation
- Flash*Freeze Technology Enables Ultra-Low Power Consumption while Maintaining FPGA Content
- Easy Entry to / Exit from Ultra-Low-Power Flash*Freeze Mode

Small Footprint Packages

- As Small as 3x3 mm in Size

Wide Range of Features

- 10 k to 250 k System Gates
- Up to 36 kbits of True Dual-Port SRAM
- Up to 71 User I/Os

Reprogrammable Flash Technology

- 130-nm, 7-Layer Metal, Flash-Based CMOS Process
- Live-at-Power-Up (LAPU) Level 0 Support
- Single-Chip Solution
- Retains Programmed Design When Powered Off

In-System Programming (ISP) and Security

- Secure ISP Using On-Chip 128-Bit Advanced Encryption Standard (AES) Decryption via JTAG (IEEE 1532-compliant)
- FlashLock[®] to Secure FPGA Contents

High-Performance Routing Hierarchy

- Segmented, Hierarchical Routing and Clock Structure

Advanced I/Os

- 1.2 V, 1.5 V, 1.8 V, 2.5 V, and 3.3 V Mixed-Voltage Operation
- Bank-Selectable I/O Voltages—up to 4 Banks per Chip
- Single-Ended I/O Standards: LVTTTL, LVCMOS 3.3 V / 2.5 V / 1.8 V / 1.5 V / 1.2 V
- Wide Range Power Supply Voltage Support per JESD8-B, Allowing I/Os to Operate from 2.7 V to 3.6 V
- Wide Range Power Supply Voltage Support per JESD8-12, Allowing I/Os to Operate from 1.14 V to 1.575 V
- I/O Registers on Input, Output, and Enable Paths
- Selectable Schmitt Trigger Inputs
- Hot-Swappable and Cold-Sparing I/Os
- Programmable Output Slew Rate and Drive Strength
- Weak Pull-Up/-Down
- IEEE 1149.1 (JTAG) Boundary Scan Test
- Pin-Compatible Packages across the IGLOO Family

Clock Conditioning Circuit (CCC) and PLL[†]

- Up to Six CCC Blocks, One with an Integrated PLL
- Configurable Phase Shift, Multiply/Divide, Delay Capabilities, and External Feedback
- Wide Input Frequency Range (1.5 MHz up to 250 MHz)

Embedded Memory

- 1 kbit of FlashROM User Nonvolatile Memory
- SRAMs and FIFOs with Variable-Aspect-Ratio 4,608-Bit RAM Blocks (x1, x2, x4, x9, and x18 organizations)[†]
- True Dual-Port SRAM (except x18 organization)[†]

Enhanced Commercial Temperature Range

- -20°C to +70°C

IGLOO nano Devices

IGLOO nano Devices	AGLN010	AGLN015	AGLN020	AGLN030 ¹	AGLN060	AGLN125	AGLN250
System Gates	10 k	15 k	20 k	30 k	60 k	125 k	250 k
Typical Equivalent Macrocells	86	128	172	256	512	1,024	2,048
VersaTiles (D-flip-flops)	260	384	520	768	1,536	3,072	6,144
Flash*Freeze Mode (typical, μ W)	2	4	4	5	10	16	24
RAM kbits (1,024 bits) ²	-	-	-	-	18	36	36
4,608-Bit Blocks ²	-	-	-	-	4	8	8
FlashROM Bits	1 k	1 k	1 k	1 k	1 k	1 k	1 k
Secure (AES) ISP ²	-	-	-	-	Yes	Yes	Yes
Integrated PLL in CCCs ²	-	-	-	-	1	1	1
VersaNet Globals ³	4	4	4	6	18	18	18
I/O Banks	2	3	3	2	2	2	4
Maximum User I/Os	34	49	52	81	71	71	68
Maximum User I/Os (Known Good Die)	34	-	52	83	71	71	68
Package Pins							
UC/CS	UC36		UC81, CS81	UC81, CS81	CS81	CS81	CS81
QFN	QN48	QN68	QN68	QN48, QN68	QN100	QN100	QN100
VQFP				VQ100	VQ100	VQ100	VQ100

Notes:

1. AGLN030 is available in the Z feature grade only and offers package compatibility with the lower density nano devices. Refer to "IGLOO nano Ordering Information" on page III.
2. AGLN060, AGLN125, and AGLN250 in the CS81 package do not support PLLs. AGLN030 and smaller devices do not support this feature.
3. Six chip (main) and three quadrant global networks are available for AGLN060 and above.
4. For higher densities and support of additional features, refer to the IGLOO and IGLOOe handbooks.

[†] AGLN030 and smaller devices do not support this feature.

I/Os Per Package

IGLOO nano Devices	AGLN010	AGLN015	AGLN020	AGLN030 ¹	AGLN060	AGLN125	AGLN250
Known Good Die	34	–	52	83	71	71	68
UC36	23						
QN48	34			34			
QN68		49	49	49			
UC81			52	66			
CS81			52	66	60	60	60
QN100					71	71	68
VQ100				77	71	71	68

Notes:

1. AGLN030 is available in the Z feature grade only and offers package compatibility with the lower density nano devices. Refer to "IGLOO nano Ordering Information" on page III.
2. When considering migrating your design to a lower- or higher-density device, refer to the IGLOO Handbook to ensure compliance with design and board migration requirements.
3. When the Flash*Freeze pin is used to directly enable Flash*Freeze mode and not used as a regular I/O, the number of single-ended user I/Os available is reduced by one.
4. "G" indicates RoHS-compliant packages. Refer to "IGLOO nano Ordering Information" on page III for the location of the "G" in the part number. For nano devices, the VQ100 package is offered in both leaded and RoHS-compliant versions. All other packages are RoHS-compliant only.

IGLOO FPGAs Package Sizes Dimensions

Packages	UC36	UC81	CS81	QN48	QN68	QN100	VQ100
Length × Width (mm \ mm)	3 x 3	4 x 4	5 x 5	6 x 6	8 x 8	8 x 8	14 x 14
Nominal Area (mm ²)	9	16	36	36	64	64	196
Pitch (mm)	0.4	0.4	0.5	0.4	0.4	0.5	0.5
Height (mm)	0.80	0.80	0.80	0.90	0.90	0.85	1.20

IGLOO nano Ordering Information

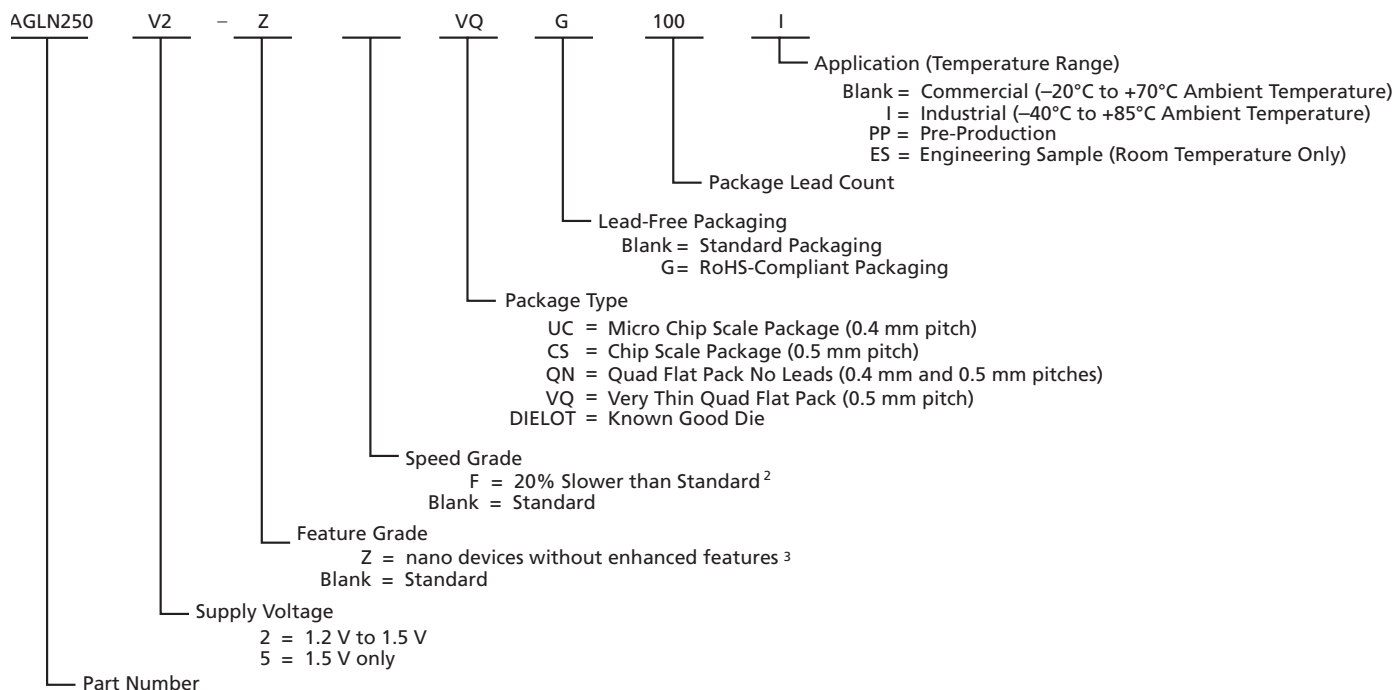

IGLOO nano Devices

AGLN010 = 10,000 System Gates
 AGLN015 = 15,000 System Gates
 AGLN020 = 20,000 System Gates
 AGLN030 = 30,000 System Gates
 AGLN060 = 60,000 System Gates
 AGLN125 = 125,000 System Gates
 AGLN250 = 250,000 System Gates

Notes:

1. **Marking Information:** IGLOO nano V2 devices do not have V2 marking, but IGLOO nano V5 devices are marked with a V5 designator.
2. **The DC and switching characteristics for the -F speed grade targets are based only on simulation. The characteristics provided for the -F speed grade are subject to change after establishing FPGA specifications. Some restrictions might be added and will be reflected in future revisions of this document. The -F speed grade is only supported in the commercial temperature range.**
3. **For the AGLN060, AGLN125, and AGLN250, the Z feature grade does not support the enhanced nano features of Schmitt trigger input, bus hold, cold-sparing, and hot-swap I/O capability. The AGLN030 Z feature grade does not support Schmitt trigger input and bus hold. For the VQ100, CS81, UC81, QN68, and QN48 packages, the Z feature grade and the N part number are not marked on the device.**

IGLOO nano Product Available in the Z Feature Grade

Devices	AGLN030	AGLN060	AGLN125	AGLN250
Packages	QN48	–	–	–
	QN68	–	–	–
	UC81	–	–	–
	CS81	CS81	CS81	–
	–	QN100	QN100	–
	VQ100	VQ100	VQ100	VQ100

Temperature Grade Offerings

Package	AGLN010	AGLN015	AGLN020	AGLN030	AGLN060	AGLN125	AGLN250
UC36	C, I	–	–	–	–	–	–
QN48	C, I	–	–	C, I	–	–	–
QN68	–	C, I	C, I	C, I	–	–	–
UC81	–	–	C, I	C, I	–	–	–
CS81	–	–	C, I	C, I	C, I	C, I	C, I
QN100	–	–	–	–	C, I	C, I	C, I
VQ100	–	–	–	C, I	C, I	C, I	C, I

Notes:

1. C = Commercial temperature range: –20°C to 70°C ambient temperature.
2. I = Industrial temperature range: –40°C to 85°C ambient temperature.

Speed Grade and Temperature Grade Matrix

Temperature Grade	–F ¹	Std.
C ²	✓	✓
I ³	–	✓

Notes:

1. The characteristics provided for the –F speed grade are subject to change after establishing FPGA specifications. Some restrictions might be added and will be reflected in future revisions of this document. The –F speed grade is supported only in the commercial temperature range.
2. C = Commercial temperature range: –20°C to 70°C ambient temperature.
3. I = Industrial temperature range: –40°C to 85°C ambient temperature.

Contact your local Actel representative for device availability: <http://www.actel.com/contact/default.aspx>.



1 – IGLOO nano Device Overview

General Description

The IGLOO family of flash FPGAs, based on a 130-nm flash process, offers the lowest power FPGA, a single-chip solution, small footprint packages, reprogrammability, and an abundance of advanced features.

The Flash*Freeze technology used in IGLOO nano devices enables entering and exiting an ultra-low-power mode that consumes nanoPower while retaining SRAM and register data. Flash*Freeze technology simplifies power management through I/O and clock management with rapid recovery to operation mode.

The Low Power Active capability (static idle) allows for ultra-low-power consumption while the IGLOO nano device is completely functional in the system. This allows the IGLOO nano device to control system power management based on external inputs (e.g., scanning for keyboard stimulus) while consuming minimal power.

Nonvolatile flash technology gives IGLOO nano devices the advantage of being a secure, low-power, single-chip solution that is live at power-up (LAPU). The IGLOO nano device is reprogrammable and offers time-to-market benefits at an ASIC-level unit cost.

These features enable designers to create high-density systems using existing ASIC or FPGA design flows and tools.

IGLOO nano devices offer 1 kbit of on-chip, reprogrammable, nonvolatile FlashROM storage as well as clock conditioning circuitry based on an integrated phase-locked loop (PLL). The AGLN030 and smaller devices have no PLL or RAM support. IGLOO nano devices have up to 250 k system gates, supported with up to 36 kbits of true dual-port SRAM and up to 71 user I/Os.

IGLOO nano devices increase the breadth of the IGLOO product line by adding new features and packages for greater customer value in high volume consumer, portable, and battery-backed markets. Features such as smaller footprint packages designed with two-layer PCBs in mind, power consumption measured in nanoPower, Schmitt trigger, and bus hold functionality make these devices ideal for deployment in applications that require high levels of flexibility and low cost.

Flash*Freeze Technology

The IGLOO nano device offers unique Flash*Freeze technology, allowing the device to enter and exit ultra-low-power Flash*Freeze mode. IGLOO nano devices do not need additional components to turn off I/Os or clocks while retaining the design information, SRAM content, and registers. Flash*Freeze technology is combined with in-system programmability, which enables users to quickly and easily upgrade and update their designs in the final stages of manufacturing or in the field. The ability of IGLOO nano V2 devices to support a wide range of core voltage (1.2 V to 1.5 V) allows further reduction in power consumption, thus achieving the lowest total system power.

During Flash*Freeze mode, each I/O can be set to the following configurations: hold previous state, tristate, HIGH, or LOW.

The availability of low-power modes, combined with reprogrammability, a single-chip and single-voltage solution, and small-footprint packages make IGLOO nano devices the best fit for portable electronics.

Flash Advantages

Low Power

Flash-based IGLOO nano devices exhibit power characteristics similar to those of an ASIC, making them an ideal choice for power-sensitive applications. IGLOO nano devices have only a very limited power-on current surge and no high-current transition period, both of which occur on many FPGAs.

IGLOO nano devices also have low dynamic power consumption to further maximize power savings; power is reduced even further by the use of a 1.2 V core voltage.

Low dynamic power consumption, combined with low static power consumption and Flash*Freeze technology, gives the IGLOO nano device the lowest total system power offered by any FPGA.

Security

Nonvolatile, flash-based IGLOO nano devices do not require a boot PROM, so there is no vulnerable external bitstream that can be easily copied. IGLOO nano devices incorporate FlashLock, which provides a unique combination of reprogrammability and design security without external overhead, advantages that only an FPGA with nonvolatile flash programming can offer.

IGLOO nano devices utilize a 128-bit flash-based lock and a separate AES key to secure programmed intellectual property and configuration data. In addition, all FlashROM data in IGLOO nano devices can be encrypted prior to loading, using the industry-leading AES-128 (FIPS192) bit block cipher encryption standard. AES was adopted by the National Institute of Standards and Technology (NIST) in 2000 and replaces the 1977 DES standard. IGLOO nano devices have a built-in AES decryption engine and a flash-based AES key that make them the most comprehensive programmable logic device security solution available today. IGLOO nano devices with AES-based security allow for secure, remote field updates over public networks such as the Internet, and ensure that valuable IP remains out of the hands of system overbuilders, system cloners, and IP thieves. The contents of a programmed IGLOO nano device cannot be read back, although secure design verification is possible.

Security, built into the FPGA fabric, is an inherent component of IGLOO nano devices. The flash cells are located beneath seven metal layers, and many device design and layout techniques have been used to make invasive attacks extremely difficult. IGLOO nano devices, with FlashLock and AES security, are unique in being highly resistant to both invasive and noninvasive attacks. Your valuable IP is protected and secure, making remote ISP possible. An IGLOO nano device provides the most impenetrable security for programmable logic designs.

Single Chip

Flash-based FPGAs store their configuration information in on-chip flash cells. Once programmed, the configuration data is an inherent part of the FPGA structure, and no external configuration data needs to be loaded at system power-up (unlike SRAM-based FPGAs). Therefore, flash-based IGLOO nano FPGAs do not require system configuration components such as EEPROMs or microcontrollers to load device configuration data. This reduces bill-of-materials costs and PCB area, and increases security and system reliability.

Live at Power-Up

Actel flash-based IGLOO nano devices support Level 0 of the LAPU classification standard. This feature helps in system component initialization, execution of critical tasks before the processor wakes up, setup and configuration of memory blocks, clock generation, and bus activity management. The LAPU feature of flash-based IGLOO nano devices greatly simplifies total system design and reduces total system cost, often eliminating the need for CPLDs and clock generation PLLs. In addition, glitches and brownouts in system power will not corrupt the IGLOO nano device's flash configuration, and unlike SRAM-based FPGAs, the device will not have to be reloaded when system power is restored. This enables the reduction or complete removal of the configuration PROM, expensive voltage monitor, brownout detection, and clock generator devices from the PCB design. Flash-based IGLOO nano devices simplify total system design and reduce cost and design risk while increasing system reliability and improving system initialization time.

IGLOO nano flash FPGAs enable the user to quickly enter and exit Flash*Freeze mode. This is done almost instantly (within 1 μ s) and the device retains configuration and data in registers and RAM.



Unlike SRAM-based FPGAs, the device does not need to reload configuration and design state from external memory components; instead it retains all necessary information to resume operation immediately.

Reduced Cost of Ownership

Advantages to the designer extend beyond low unit cost, performance, and ease of use. Unlike SRAM-based FPGAs, flash-based IGLOO nano devices allow all functionality to be live at power-up; no external boot PROM is required. On-board security mechanisms prevent access to all the programming information and enable secure remote updates of the FPGA logic. Designers can perform secure remote in-system reprogramming to support future design iterations and field upgrades with confidence that valuable intellectual property cannot be compromised or copied. Secure ISP can be performed using the industry-standard AES algorithm. The IGLOO nano device architecture mitigates the need for ASIC migration at higher user volumes. This makes IGLOO nano devices cost-effective ASIC replacement solutions, especially for applications in the consumer, networking/communications, computing, and avionics markets.

With a variety of devices under \$1, Actel IGLOO nano FPGAs enable cost-effective implementation of programmable logic and quick time to market.

Firm-Error Immunity

Firm errors occur most commonly when high-energy neutrons, generated in the upper atmosphere, strike a configuration cell of an SRAM FPGA. The energy of the collision can change the state of the configuration cell and thus change the logic, routing, or I/O behavior in an unpredictable way. These errors are impossible to prevent in SRAM FPGAs. The consequence of this type of error can be a complete system failure. Firm errors do not exist in the configuration memory of IGLOO nano flash-based FPGAs. Once it is programmed, the flash cell configuration element of IGLOO nano FPGAs cannot be altered by high-energy neutrons and is therefore immune to them. Recoverable (or soft) errors occur in the user data SRAM of all FPGA devices. These can easily be mitigated by using error detection and correction (EDAC) circuitry built into the FPGA fabric.

Advanced Flash Technology

The IGLOO nano device offers many benefits, including nonvolatility and reprogrammability, through an advanced flash-based, 130-nm LVCMOS process with seven layers of metal. Standard CMOS design techniques are used to implement logic and control functions. The combination of fine granularity, enhanced flexible routing resources, and abundant flash switches allows for very high logic utilization without compromising device routability or performance. Logic functions within the device are interconnected through a four-level routing hierarchy.

IGLOO nano FPGAs utilize design and process techniques to minimize power consumption in all modes of operation.

Advanced Architecture

The proprietary IGLOO nano architecture provides granularity comparable to standard-cell ASICs. The IGLOO nano device consists of five distinct and programmable architectural features (Figure 1-3 on page 1-5 to Figure 1-4 on page 1-5):

- Flash*Freeze technology
- FPGA VersaTiles
- Dedicated FlashROM
- Dedicated SRAM/FIFO memory[†]
- Extensive CCCs and PLLs[†]
- Advanced I/O structure

The FPGA core consists of a sea of VersaTiles. Each VersaTile can be configured as a three-input logic function, a D-flip-flop (with or without enable), or a latch by programming the appropriate flash switch interconnections. The versatility of the IGLOO nano core tile as either a three-input lookup table (LUT) equivalent or a D-flip-flop/latch with enable allows for efficient use of the FPGA fabric. The VersaTile capability is unique to the Actel ProASIC® family of third-generation-

[†] The AGLN030 and smaller devices do not support PLL or SRAM.

architecture flash FPGAs. VersaTiles are connected with any of the four levels of routing hierarchy. Flash switches are distributed throughout the device to provide nonvolatile, reconfigurable interconnect programming. Maximum core utilization is possible for virtually any design.

In addition, extensive on-chip programming circuitry enables rapid, single-voltage (3.3 V) programming of IGLOO nano devices via an IEEE 1532 JTAG interface.

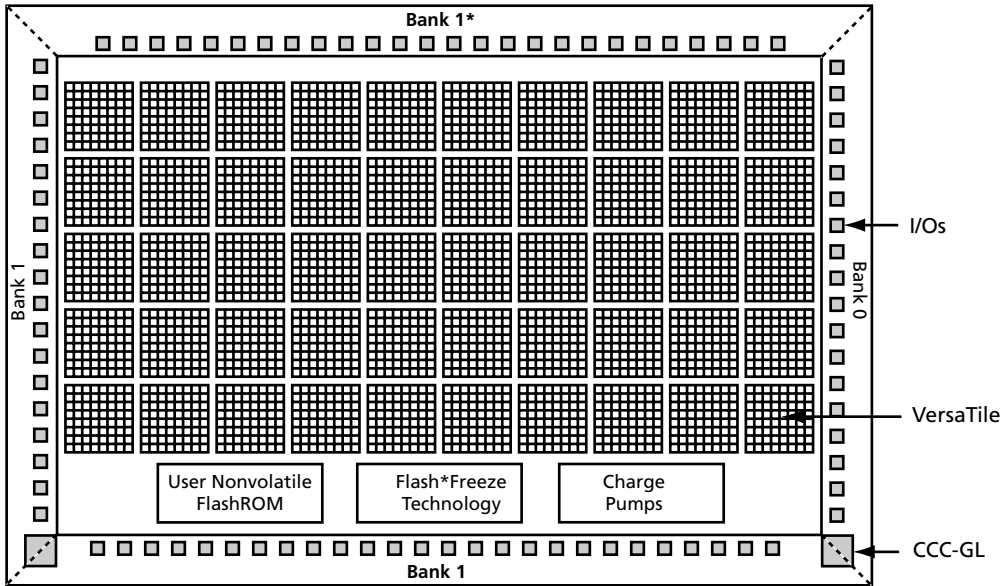

Note: *Bank 0 for the AGLN030 device

Figure 1-1 • IGLOO Device Architecture Overview with Two I/O Banks and No RAM (AGLN010 and AGLN030)

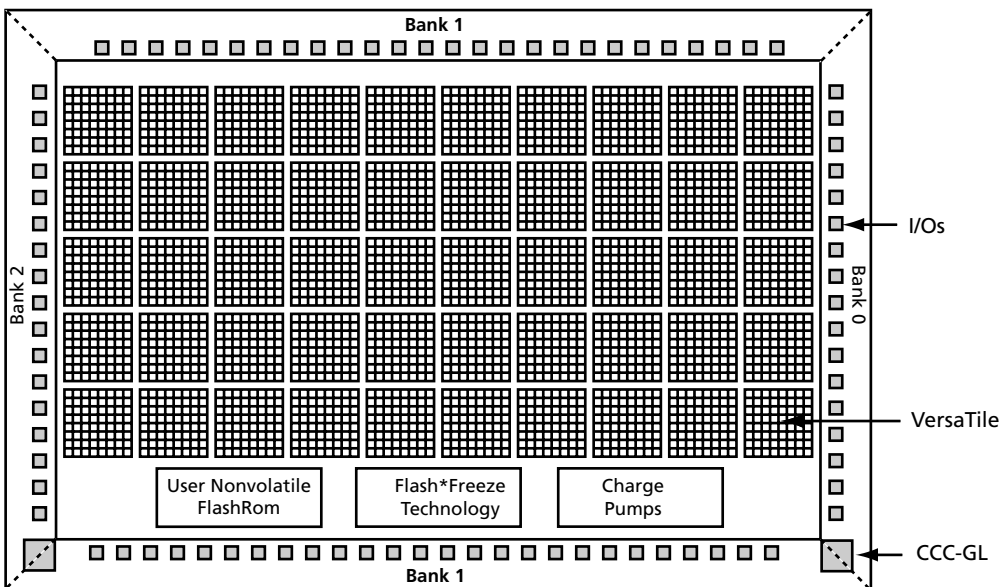

Figure 1-2 • IGLOO Device Architecture Overview with Three I/O Banks and No RAM (AGLN015 and AGLN020)

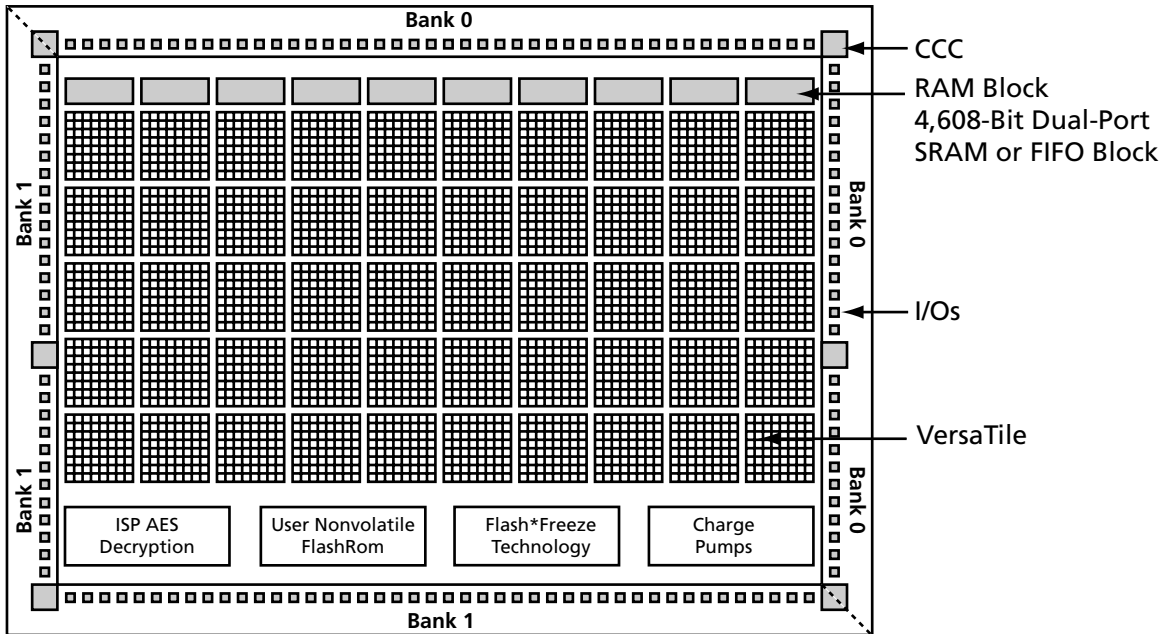

Figure 1-3 • IGLOO Device Architecture Overview with Two I/O Banks (AGLN060, AGLN125)

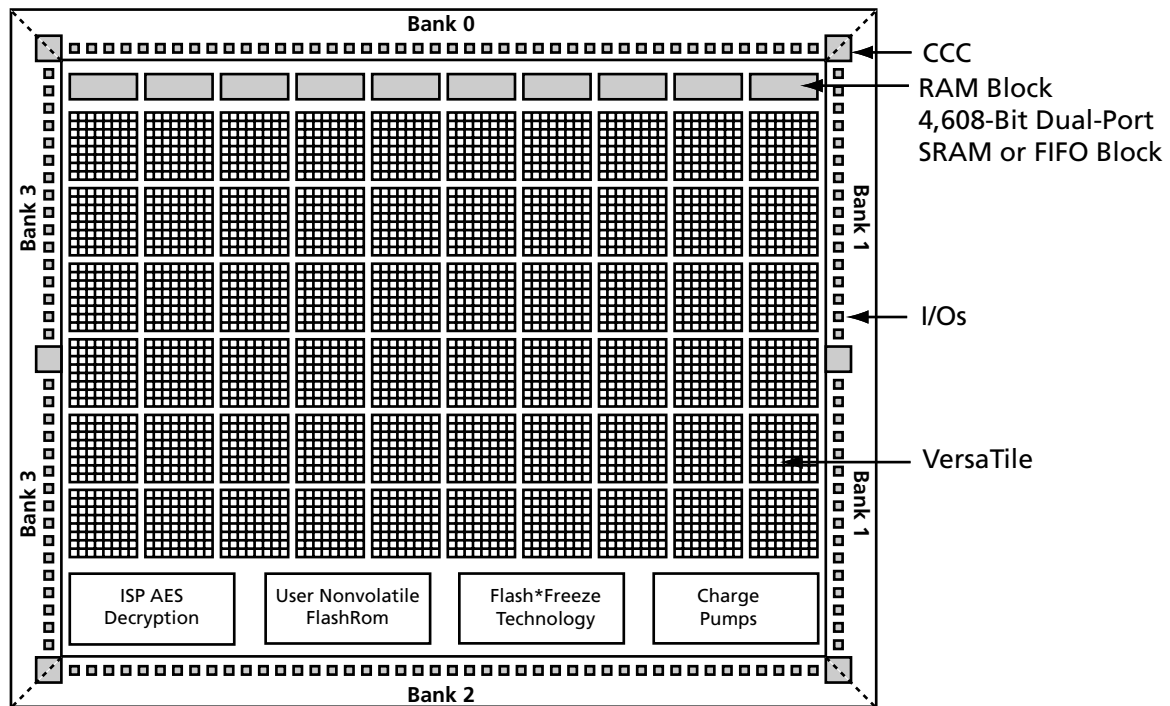

Figure 1-4 • IGLOO Device Architecture Overview with Four I/O Banks (AGLN250)

Flash*Freeze Technology

The IGLOO nano device has an ultra-low-power static mode, called Flash*Freeze mode, which retains all SRAM and register information and can still quickly return to normal operation. Flash*Freeze technology enables the user to quickly (within 1 μ s) enter and exit Flash*Freeze mode by activating the Flash*Freeze pin while all power supplies are kept at their original values. I/Os, global I/Os, and clocks can still be driven and can be toggling without impact on power consumption, and the device retains all core registers, SRAM information, and I/O states. I/Os can be individually configured to either hold their previous state or be tristated during Flash*Freeze mode.

Alternatively, I/Os can be set to a specific state using weak pull-up or pull-down I/O attribute configuration. No power is consumed by the I/O banks, clocks, JTAG pins, or PLL, and the device consumes as little as 2 μ W in this mode.

Flash*Freeze technology allows the user to switch to Active mode on demand, thus simplifying the power management of the device.

The Flash*Freeze pin (active low) can be routed internally to the core to allow the user's logic to decide when it is safe to transition to this mode. Refer to Figure 1-5 for an illustration of entering/exiting Flash*Freeze mode. It is also possible to use the Flash*Freeze pin as a regular I/O if Flash*Freeze mode usage is not planned.

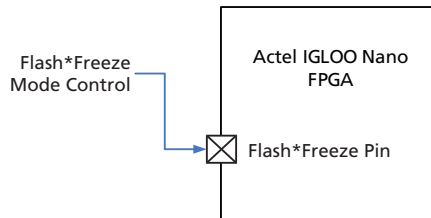

Figure 1-5 • IGLOO nano Flash*Freeze Mode

VersaTiles

The IGLOO nano core consists of VersaTiles, which have been enhanced beyond the ProASIC^{PLUS}® core tiles. The IGLOO nano VersaTile supports the following:

- All 3-input logic functions—LUT-3 equivalent
- Latch with clear or set
- D-flip-flop with clear or set
- Enable D-flip-flop with clear or set

Refer to Figure 1-6 for VersaTile configurations.

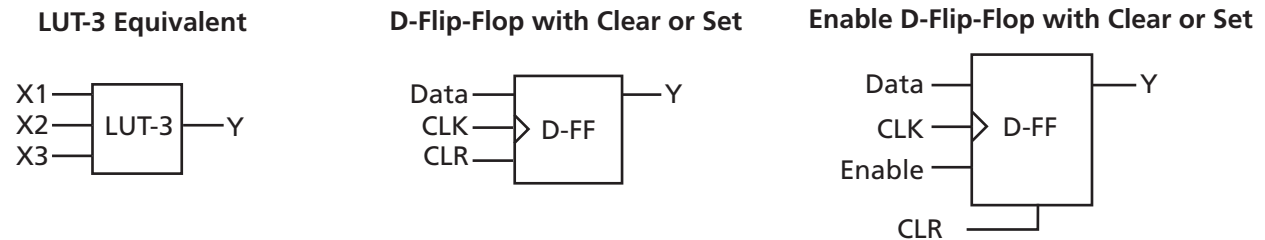

Figure 1-6 • VersaTile Configurations

User Nonvolatile FlashROM

Actel IGLOO nano devices have 1 kbit of on-chip, user-accessible, nonvolatile FlashROM. The FlashROM can be used in diverse system applications:

- Internet protocol addressing (wireless or fixed)
- System calibration settings
- Device serialization and/or inventory control
- Subscription-based business models (for example, set-top boxes)
- Secure key storage for secure communications algorithms
- Asset management/tracking
- Date stamping
- Version management

The FlashROM is written using the standard IGLOO nano IEEE 1532 JTAG programming interface. The core can be individually programmed (erased and written), and on-chip AES decryption can be used selectively to securely load data over public networks (except in the AGLN030 and smaller devices), as in security keys stored in the FlashROM for a user design.

The FlashROM can be programmed via the JTAG programming interface, and its contents can be read back either through the JTAG programming interface or via direct FPGA core addressing. Note that the FlashROM can only be programmed from the JTAG interface and cannot be programmed from the internal logic array.

The FlashROM is programmed as 8 banks of 128 bits; however, reading is performed on a byte-by-byte basis using a synchronous interface. A 7-bit address from the FPGA core defines which of the 8 banks and which of the 16 bytes within that bank are being read. The three most significant bits (MSBs) of the FlashROM address determine the bank, and the four least significant bits (LSBs) of the FlashROM address define the byte.

The Actel IGLOO nano development software solutions, Libero® Integrated Design Environment (IDE) and Designer, have extensive support for the FlashROM. One such feature is auto-generation of sequential programming files for applications requiring a unique serial number in each part. Another feature enables the inclusion of static data for system version control. Data for the FlashROM can be generated quickly and easily using Actel Libero IDE and Designer software tools. Comprehensive programming file support is also included to allow for easy programming of large numbers of parts with differing FlashROM contents.

SRAM and FIFO

IGLOO nano devices (except the AGLN030 and smaller devices) have embedded SRAM blocks along their north and south sides. Each variable-aspect-ratio SRAM block is 4,608 bits in size. Available memory configurations are 256×18, 512×9, 1k×4, 2k×2, and 4k×1 bits. The individual blocks have independent read and write ports that can be configured with different bit widths on each port. For example, data can be sent through a 4-bit port and read as a single bitstream. The embedded SRAM blocks can be initialized via the device JTAG port (ROM emulation mode) using the UJTAG macro (except in the AGLN030 and smaller devices).

In addition, every SRAM block has an embedded FIFO control unit. The control unit allows the SRAM block to be configured as a synchronous FIFO without using additional core VersaTiles. The FIFO width and depth are programmable. The FIFO also features programmable Almost Empty (AEMPTY) and Almost Full (AFULL) flags in addition to the normal Empty and Full flags. The embedded FIFO control unit contains the counters necessary for generation of the read and write address pointers. The embedded SRAM/FIFO blocks can be cascaded to create larger configurations.

PLL and CCC

Higher density IGLOO nano devices using either the two I/O bank or four I/O bank architectures provide designers with very flexible clock conditioning capabilities. AGLN060, AGLN125, and AGLN250 contain six CCCs. One CCC (center west side) has a PLL. The AGLN030 and smaller devices use different CCCs in their architecture (CCC-GL). These CCC-GLs contain a global MUX but do not have any PLLs or programmable delays.

For devices using the six CCC block architecture, these are located at the four corners and the centers of the east and west sides. All six CCC blocks are usable; the four corner CCCs and the east CCC allow simple clock delay operations as well as clock spine access.

The inputs of the six CCC blocks are accessible from the FPGA core or from dedicated connections to the CCC block, which are located near the CCC.

The CCC block has these key features:

- Wide input frequency range (f_{IN_CCC}) = 1.5 MHz up to 250 MHz
- Output frequency range (f_{OUT_CCC}) = 0.75 MHz up to 250 MHz
- 2 programmable delay types for clock skew minimization
- Clock frequency synthesis (for PLL only)

Additional CCC specifications:

- Internal phase shift = 0°, 90°, 180°, and 270°. Output phase shift depends on the output divider configuration (for PLL only).
- Output duty cycle = 50% \pm 1.5% or better (for PLL only)
- Low output jitter: worst case < 2.5% \times clock period peak-to-peak period jitter when single global network used (for PLL only)
- Maximum acquisition time is 300 μ s (for PLL only)
- Exceptional tolerance to input period jitter—allowable input jitter is up to 1.5 ns (for PLL only)
- Four precise phases; maximum misalignment between adjacent phases of 40 ps \times 250 MHz / f_{OUT_CCC} (for PLL only)

Global Clocking

IGLOO nano devices have extensive support for multiple clocking domains. In addition to the CCC and PLL support described above, there is a comprehensive global clock distribution network.

Each VersaTile input and output port has access to nine VersaNets: six chip (main) and three quadrant global networks. The VersaNets can be driven by the CCC or directly accessed from the core via multiplexers (MUXes). The VersaNets can be used to distribute low-skew clock signals or for rapid distribution of high-fanout nets.

I/Os with Advanced I/O Standards

IGLOO nano FPGAs feature a flexible I/O structure, supporting a range of voltages (1.2 V, 1.5 V, 1.8 V, 2.5 V, 3.0 V wide range, and 3.3 V).

The I/Os are organized into banks with two, three, or four banks per device. The configuration of these banks determines the I/O standards supported.

Each I/O module contains several input, output, and enable registers. These registers allow the implementation of various single-data-rate applications for all versions of nano devices and double-data-rate applications for the AGLN060, AGLN125, and AGLN250 devices.

IGLOO nano devices support LVTTLL and LVCMOS I/O standards, are hot-swappable, and support cold-sparing and Schmitt trigger.

Wide Range I/O Support

Actel nano devices support JEDEC-defined wide range I/O operation. IGLOO nano devices support both the JESD8-B specification, covering both 3 V and 3.3 V supplies, for an effective operating range of 2.7 V to 3.6 V, and JESD8-12 with its 1.2 V nominal, supporting an effective operating range of 1.14 V to 1.575 V.

Wider I/O range means designers can eliminate power supplies or power conditioning components from the board or move to less costly components with greater tolerances. Wide range eases I/O bank management and provides enhanced protection from system voltage spikes, while providing the flexibility to easily run custom voltage applications.

Part Number and Revision Date

Part Number 51700110-001-3
Revised December 2008

List of Changes

The following table lists critical changes that were made in the current version of the document.

Previous Version	Changes in Current Version (Advance v0.4)	Page
Advance v0.3 (November 2008)	The second table note in the "IGLOO nano Devices" table was revised to state, "AGLN060, AGLN125, and AGLN250 in the CS81 package do not support PLLs. AGLN030 and smaller devices do not support this feature."	I
	The I/Os per package for CS81 were revised to 60 for AGLN060, AGLN125, and AGLN250 in the "I/Os Per Package" table.	II
Advance v0.2 (October 2008)	The "Advanced I/Os" section was updated to include wide power supply voltage support for 1.14 V to 1.575 V.	I
	The AGLN030 device was added to product tables and replaces AGL030 entries that were formerly in the tables.	I to IV
	The "I/Os Per Package" table was updated for the CS81 package to change the number of I/Os for AGLN060, AGLN125, and AGLN250 from 66 to 64.	II
	The "Wide Range I/O Support" section is new.	1-8
Advance v0.1 (October 2008)	The following tables and sections were updated to add the UC81 and CS81 packages for AGL030: "IGLOO nano Devices" "I/Os Per Package" "IGLOO nano Product Available in the Z Feature Grade" "Temperature Grade Offerings"	N/A
	The "I/Os Per Package" table was updated to add the following information to table note 4: "For nano devices, the VQ100 package is offered in both leaded and RoHS-compliant versions. All other packages are RoHS-compliant only."	II
	The "IGLOO nano Product Available in the Z Feature Grade" section was updated to remove QN100 for AGLN250.	IV
	The device architecture figures, Figure 1-3 · IGLOO Device Architecture Overview with Two I/O Banks (AGLN060, AGLN125) through Figure 1-4 · IGLOO Device Architecture Overview with Four I/O Banks (AGLN250), were revised. Figure 1-1 · IGLOO Device Architecture Overview with Two I/O Banks and No RAM (AGLN010 and AGLN030) is new.	1-4 through 1-5
	The "PLL and CCC" section was revised to include information about CCC-GLs in AGLN020 and smaller devices.	1-7
	The "I/Os with Advanced I/O Standards" section was revised to add information about IGLOO nano devices supporting double-data-rate applications.	1-8

Datasheet Categories

Categories

In order to provide the latest information to designers, some datasheets are published before data has been fully characterized. Datasheets are designated as "Product Brief," "Advance," "Preliminary," and "Production." The definition of these categories are as follows:

Product Brief

The product brief is a summarized version of a datasheet (advance or production) and contains general product information. This document gives an overview of specific device and family information.

Advance

This version contains initial estimated information based on simulation, other products, devices, or speed grades. This information can be used as estimates, but not for production. This label only applies to the DC and Switching Characteristics chapter of the datasheet and will only be used when the data has not been fully characterized.

Preliminary

The datasheet contains information based on simulation and/or initial characterization. The information is believed to be correct, but changes are possible.

Unmarked (production)

This version contains information that is considered to be final.

Export Administration Regulations (EAR)

The products described in this document are subject to the Export Administration Regulations (EAR). They could require an approved export license prior to export from the United States. An export includes release of product or disclosure of technology to a foreign national inside or outside the United States.

Actel Safety Critical, Life Support, and High-Reliability Applications Policy

The Actel products described in this advance status document may not have completed Actel's qualification process. Actel may amend or enhance products during the product introduction and qualification process, resulting in changes in device functionality or performance. It is the responsibility of each customer to ensure the fitness of any Actel product (but especially a new product) for a particular purpose, including appropriateness for safety-critical, life-support, and other high-reliability applications. Consult Actel's Terms and Conditions for specific liability exclusions relating to life-support applications. A reliability report covering all of Actel's products is available on the Actel website at http://www.actel.com/documents/ORT_Report.pdf. Actel also offers a variety of enhanced qualification and lot acceptance screening procedures. Contact your local Actel sales office for additional reliability information.

2 – IGLOO nano DC and Switching Characteristics

General Specifications

The Z feature grade does not support the enhanced nano features of Schmitt trigger input, Flash*Freeze bus hold, cold-sparing, and hot-swap I/O capability. Refer to the ordering information in the *IGLOO nano Product Brief* for more information.

DC and switching characteristics for –F speed grade targets are based only on simulation.

The characteristics provided for the –F speed grade are subject to change after establishing FPGA specifications. Some restrictions might be added and will be reflected in future revisions of this document. The –F speed grade is only supported in the commercial temperature range.

Operating Conditions

Stresses beyond those listed in [Table 2-1](#) may cause permanent damage to the device.

Exposure to absolute maximum rating conditions for extended periods may affect device reliability. Absolute Maximum Ratings are stress ratings only; functional operation of the device at these or any other conditions beyond those listed under the Recommended Operating Conditions specified in [Table 2-2](#) on [page 2-2](#) is not implied.

Table 2-1 • Absolute Maximum Ratings

Symbol	Parameter	Limits	Units
V _{CC}	DC core supply voltage	–0.3 to 1.65	V
V _{JTAG}	JTAG DC voltage	–0.3 to 3.75	V
V _{PUMP}	Programming voltage	–0.3 to 3.75	V
V _{CCPLL}	Analog power supply (PLL)	–0.3 to 1.65	V
V _{CCI}	DC I/O buffer supply voltage	–0.3 to 3.75	V
V _I	I/O input voltage	–0.3 V to 3.6 V	V
T _{STG} ²	Storage temperature	–65 to +150	°C
T _J ²	Junction temperature	+125	°C

Notes:

1. The device should be operated within the limits specified by the datasheet. During transitions, the input signal may undershoot or overshoot according to the limits shown in [Table 2-4](#) on [page 2-3](#).
2. For flash programming and retention maximum limits, refer to [Table 2-3](#) on [page 2-2](#), and for recommended operating limits, refer to [Table 2-2](#) on [page 2-2](#).

Table 2-2 • Recommended Operating Conditions ¹

Symbol	Parameter		Extended Commercial	Industrial	Units
T _A	Ambient temperature		-20 to +70 ²	-40 to +85 ²	°C
T _J	Junction temperature		-20 to + 85 ²	-40 to +100 ²	°C
V _{CC}	1.5 V DC core supply voltage ³		1.425 to 1.575	1.425 to 1.575	V
	1.2 V–1.5 V wide range core voltage ⁴		1.14 to 1.575	1.14 to 1.575	V
V _{JTAG}	JTAG DC voltage		1.425 to 3.6	1.425 to 3.6	V
V _{PUMP} ⁵	Programming voltage	Programming mode	3.15 to 3.45	3.15 to 3.45	V
		Operation	0 to 3.45	0 to 3.45	V
V _{CCPLL} ⁶	Analog power supply (PLL)	1.5 V DC core supply voltage ³	1.425 to 1.575	1.425 to 1.575	V
		1.2 V–1.5 V wide range core supply voltage ⁴	1.14 to 1.575	1.14 to 1.575	V
V _{CCI} and VMV ^{7,9}	1.2 V DC supply voltage ⁴		1.14 to 1.26	1.14 to 1.26	V
	1.2 V DC wide range supply voltage ⁴		1.14 to 1.575	1.14 to 1.575	V
	1.5 V DC supply voltage		1.425 to 1.575	1.425 to 1.575	
	1.8 V DC supply voltage		1.7 to 1.9	1.7 to 1.9	V
	2.5 V DC supply voltage		2.3 to 2.7	2.3 to 2.7	V
	3.3 V DC supply voltage		3.0 to 3.6	3.0 to 3.6	V
	3.3 V DC wide range supply voltage ⁸		2.7 to 3.6	2.7 to 3.6	

Notes:

1. All parameters representing voltages are measured with respect to GND unless otherwise specified.
2. To ensure targeted reliability standards are met across ambient and junction operating temperatures, Actel recommends that the user follow best design practices using Actel's timing and power simulation tools.
3. For IGLOO® nano V5 devices
4. For IGLOO nano V2 devices only, operating at $V_{CCI} \geq V_{CC}$
5. V_{PUMP} can be left floating during operation (not programming mode).
6. V_{CCPLL} pins should be tied to V_{CC} pins. See [Pin Descriptions](#) for further information.
7. VMV pins must be connected to the corresponding V_{CCI} pins. See [Pin Descriptions](#) for further information.
8. 3.3 V wide range is compliant to the JESD8-B specification and supports 3.0 V V_{CCI} operation.
9. The ranges given here are for power supplies only. The recommended input voltage ranges specific to each I/O standard are given in [Table 2-20 on page 2-19](#). V_{CCI} should be at the same voltage within a given I/O bank.

Table 2-3 • Flash Programming Limits – Retention, Storage, and Operating Temperature ¹

Product Grade	Programming Cycles	Program Retention (biased/unbiased)	Maximum Storage Temperature T _{STG} (°C) ²	Maximum Operating Junction Temperature T _J (°C) ²
Commercial	500	20 years	110	100
Industrial	500	20 years	110	100

Notes:

1. This is a stress rating only; functional operation at any condition other than those indicated is not implied.
2. These limits apply for program/data retention only. Refer to [Table 2-1 on page 2-1](#) and [Table 2-2](#) for device operating conditions and absolute limits.



Table 2-4 • Overshoot and Undershoot Limits¹

V _{CCI}	Average V _{CCI} -GND Overshoot or Undershoot Duration as a Percentage of Clock Cycle ²	Maximum Overshoot/Undershoot ²
2.7 V or less	10%	1.4 V
	5%	1.49 V
3 V	10%	1.1 V
	5%	1.19 V
3.3 V	10%	0.79 V
	5%	0.88 V
3.6 V	10%	0.45 V
	5%	0.54 V

Notes:

1. Based on reliability requirements at 85°C.
2. The duration is allowed at one out of six clock cycles. If the overshoot/undershoot occurs at one out of two cycles, the maximum overshoot/undershoot has to be reduced by 0.15 V.

I/O Power-Up and Supply Voltage Thresholds for Power-On Reset (Commercial and Industrial)

Sophisticated power-up management circuitry is designed into every IGLOO nano device. These circuits ensure easy transition from the powered-off state to the powered-up state of the device. The many different supplies can power up in any sequence with minimized current spikes or surges. In addition, the I/O will be in a known state through the power-up sequence. The basic principle is shown in Figure 2-1 on page 2-4.

There are five regions to consider during power-up.

IGLOO nano I/Os are activated only if ALL of the following three conditions are met:

1. V_{CC} and V_{CCI} are above the minimum specified trip points (Figure 2-1 and Figure 2-2 on page 2-5).
2. V_{CCI} > V_{CC} - 0.75 V (typical)
3. Chip is in the operating mode.

V_{CCI} Trip Point:

Ramping up (V5 devices): 0.6 V < trip_point_up < 1.2 V

Ramping down (V5 devices): 0.5 V < trip_point_down < 1.1 V

Ramping up (V2 devices): 0.75 V < trip_point_up < 1.05 V

Ramping down (V2 devices): 0.65 V < trip_point_down < 0.95 V

V_{CC} Trip Point:

Ramping up (V5 devices): 0.6 V < trip_point_up < 1.1 V

Ramping down (V5 devices): 0.5 V < trip_point_down < 1.0 V

Ramping up (V2 devices): 0.65 V < trip_point_up < 1.05 V

Ramping down (V2 devices): 0.55 V < trip_point_down < 0.95 V

V_{CC} and V_{CCI} ramp-up trip points are about 100 mV higher than ramp-down trip points. This specifically built-in hysteresis prevents undesirable power-up oscillations and current surges. Note the following:

- During programming, I/Os become tristated and weakly pulled up to V_{CCI}.
- JTAG supply, PLL power supplies, and charge pump V_{PUMP} supply have no influence on I/O behavior.

PLL Behavior at Brownout Condition

Actel recommends using monotonic power supplies or voltage regulators to ensure proper power-up behavior. Power ramp-up should be monotonic at least until V_{CC} and V_{CCPLX} exceed brownout activation levels (see Figure 2-1 and Figure 2-2 on page 2-5 for more details).

When PLL power supply voltage and/or V_{CC} levels drop below the V_{CC} brownout levels ($0.75\text{ V} \pm 0.25\text{ V}$ for V5 devices, and $0.75\text{ V} \pm 0.2\text{ V}$ for V2 devices), the PLL output lock signal goes LOW and/or the output clock is lost. Refer to the "Brownout Voltage" section in the *Power-Up/Down Behavior of Low-Power Flash Devices* chapter of the *ProASIC3* and *ProASIC3E* handbooks for information on clock and lock recovery.

Internal Power-Up Activation Sequence

1. Core
2. Input buffers
3. Output buffers, after 200 ns delay from input buffer activation

To make sure the transition from input buffers to output buffers is clean, ensure that there is no path longer than 100 ns from input buffer to output buffer in your design.

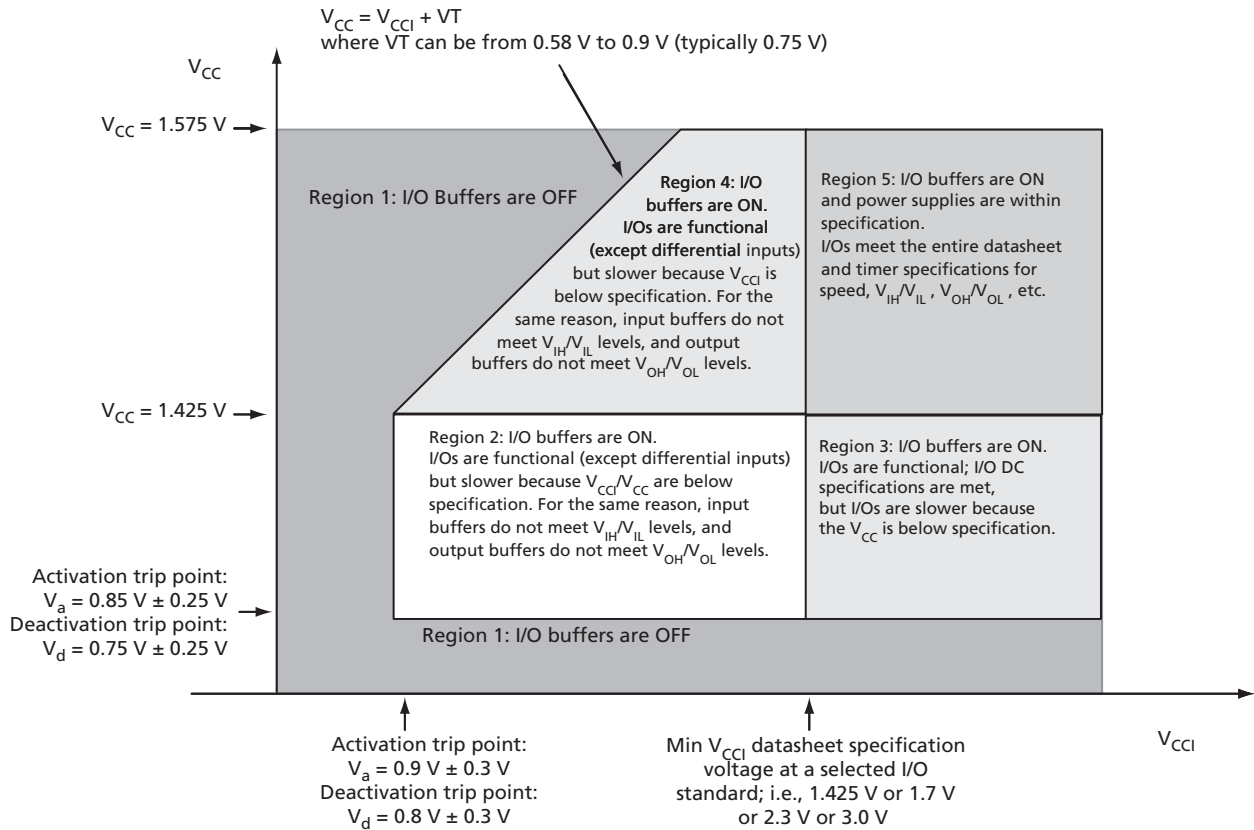
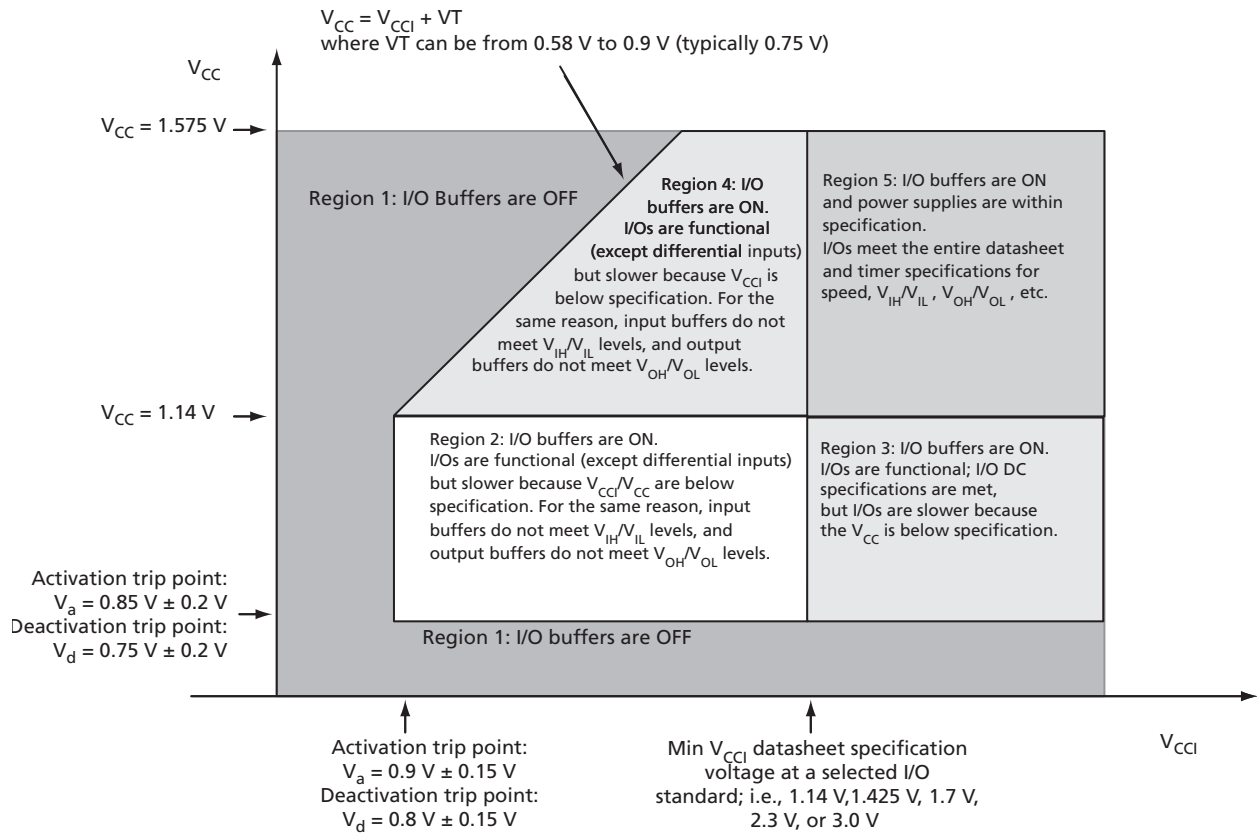

Figure 2-1 • V5 Devices – I/O State as a Function of V_{CCI} and V_{CC} Voltage Levels

Figure 2-2 • V2 Devices – I/O State as a Function of V_{CCI} and V_{CC} Voltage Levels

Thermal Characteristics

Introduction

The temperature variable in the Actel Designer software refers to the junction temperature, not the ambient temperature. This is an important distinction because dynamic and static power consumption cause the chip junction temperature to be higher than the ambient temperature.

EQ 2-1 can be used to calculate junction temperature.

$$T_J = \text{Junction Temperature} = \Delta T + T_A$$

EQ 2-1

where:

T_A = Ambient temperature

ΔT = Temperature gradient between junction (silicon) and ambient $\Delta T = \theta_{ja} * P$

θ_{ja} = Junction-to-ambient of the package. θ_{ja} numbers are located in Figure 2-5.

P = Power dissipation

Package Thermal Characteristics

The device junction-to-case thermal resistivity is θ_{jc} and the junction-to-ambient air thermal resistivity is θ_{ja} . The thermal characteristics for θ_{ja} are shown for two air flow rates. The maximum operating junction temperature is 100°C. EQ 2-2 shows a sample calculation of the maximum operating power dissipation allowed for a 484-pin FBGA package at commercial temperature and in still air.

$$\text{Maximum Power Allowed} = \frac{\text{Max. junction temp. (}^\circ\text{C)} - \text{Max. ambient temp. (}^\circ\text{C)}}{\theta_{ja} (^\circ\text{C/W)}} = \frac{100^\circ\text{C} - 70^\circ\text{C}}{20.5^\circ\text{C/W}} = 1.46\text{ W}$$

EQ 2-2

Table 2-5 • Package Thermal Resistivities

Package Type	Pin Count	θ_{jc}	θ_{ja}			Units
			Still Air	200 ft./min.	500 ft./min.	
Chip Scale Package (CSP)	36	TBD	TBD	TBD	TBD	C/W
	81	TBD	TBD	TBD	TBD	C/W
Quad Flat No Lead (QFN)	48	TBD	TBD	TBD	TBD	C/W
	68	TBD	TBD	TBD	TBD	C/W
	100	TBD	TBD	TBD	TBD	C/W
Very Thin Quad Flat Pack (VQFP)	100	10.0	35.3	29.4	27.1	C/W

Temperature and Voltage Derating Factors

Table 2-6 • Temperature and Voltage Derating Factors for Timing Delays (normalized to $T_J = 70^\circ\text{C}$, $V_{CC} = 1.425\text{ V}$)
For IGLOO nano V2 or V5 Devices, 1.5 V DC Core Supply Voltage

Array Voltage V_{CC} (V)	Junction Temperature ($^\circ\text{C}$)						
	-40 $^\circ\text{C}$	-20 $^\circ\text{C}$	0 $^\circ\text{C}$	25 $^\circ\text{C}$	70 $^\circ\text{C}$	85 $^\circ\text{C}$	125 $^\circ\text{C}$
1.425	0.966	0.972	0.977	0.991	1.000	1.006	1.013
1.5	0.877	0.882	0.888	0.899	0.907	0.913	0.919
1.575	0.815	0.820	0.824	0.835	0.843	0.848	0.854



**Table 2-7 • Temperature and Voltage Derating Factors for Timing Delays (normalized to $T_J = 70^\circ\text{C}$, $V_{CC} = 1.14\text{ V}$)
For IGLOO nano V2, 1.2 V DC Core Supply Voltage**

Array Voltage V_{CC} (V)	Junction Temperature ($^\circ\text{C}$)						
	-40°C	-20°C	0°C	25°C	70°C	85°C	110°C
1.14	0.968	0.973	0.978	0.991	1.000	1.006	1.012
1.2	0.863	0.869	0.874	0.885	0.892	0.898	0.904
1.26	0.793	0.798	0.802	0.812	0.820	0.825	0.830
1.3	0.746	0.750	0.754	0.764	0.771	0.776	0.781
1.35	0.690	0.694	0.698	0.707	0.714	0.718	0.723
1.425	0.615	0.618	0.622	0.630	0.636	0.640	0.644
1.5	0.558	0.561	0.565	0.572	0.577	0.581	0.585
1.575	0.519	0.522	0.525	0.532	0.536	0.540	0.543

Calculating Power Dissipation

Quiescent Supply Current

Quiescent supply current (I_{DD}) calculation depends on multiple factors, including operating voltages (V_{CC} , V_{CCI} , and V_{JTAG}), operating temperature, system clock frequency, and power mode usage. Actel recommends using the Power Calculator and SmartPower software estimation tools to evaluate the projected static and active power based on the user design, power mode usage, operating voltage, and temperature.

Table 2-8 • Quiescent Supply Current (I_{DD}) Characteristics, IGLOO nano Flash*Freeze Mode*

	Core Voltage	AGLN010	AGLN015	AGLN020	AGLN060	AGLN125	AGLN250	Units
Typical (25°C)	1.2 V	1.7	3.3	3.3	8	13	20	μA
	1.5 V	3	6	6	10	18	34	μA

* I_{DD} includes V_{CC} , V_{PUMP} , V_{CCI} , V_{JTAG} , and V_{CCPLL} currents.

Table 2-9 • Quiescent Supply Current (I_{DD}) Characteristics, IGLOO nano Sleep Mode ($V_{CC} = 0\text{ V}$)*

	Core Voltage	AGLN010	AGLN015	AGLN020	AGLN060	AGLN125	AGLN250	Units
$V_{CCI}/V_{JTAG} = 1.2\text{ V}$ (per bank) Typical (25°C)	1.2 V	1.7	1.7	1.7	1.7	1.7	1.7	μA
$V_{CCI}/V_{JTAG} = 1.5\text{ V}$ (per bank) Typical (25°C)	1.2 V / 1.5 V	1.8	1.8	1.8	1.8	1.8	1.8	μA
$V_{CCI}/V_{JTAG} = 1.8\text{ V}$ (per bank) Typical (25°C)	1.2 V / 1.5 V	1.9	1.9	1.9	1.9	1.9	1.9	μA
$V_{CCI}/V_{JTAG} = 2.5\text{ V}$ (per bank) Typical (25°C)	1.2 V / 1.5 V	2.2	2.2	2.2	2.2	2.2	2.2	μA
$V_{CCI}/V_{JTAG} = 3.3\text{ V}$ (per bank) Typical (25°C)	1.2 V / 1.5 V	2.5	2.5	2.5	2.5	2.5	2.5	μA

* I_{DD} includes V_{CC} , V_{PUMP} , and V_{CCPLL} currents.

Table 2-10 • Quiescent Supply Current (I_{DD}) Characteristics, IGLOO nano Shutdown Mode ($V_{CC}, V_{CCI} = 0\text{ V}$)*

	Core Voltage	AGLN010	AGLN015	AGLN020	AGLN060	AGLN125	AGLN250	Units
Typical (25°C)	1.2 V / 1.5 V	0	0	0	0	0	0	μA

* I_{DD} includes $V_{CC}, V_{PUMP}, V_{CCI}$, and V_{CCPLL} currents.

Table 2-11 • Quiescent Supply Current (I_{DD}), No IGLOO nano Flash*Freeze Mode¹

	Core Voltage	AGLN010	AGLN015	AGLN020	AGLN060	AGLN125	AGLN250	Units
I_{CCA} Current²								
Typical (25°C)	1.2 V	3.7	5	5	10	13	18	μA
	1.5 V	8	14	14	20	28	44	μA
I_{CCI} or I_{JTAG} Current³								
$V_{CCI} / V_{JTAG} = 1.2\text{ V}$ (per bank) Typical (25°C)	1.2 V	1.7	1.7	1.7	1.7	1.7	1.7	μA
$V_{CCI} / V_{JTAG} = 1.5\text{ V}$ (per bank) Typical (25°C)	1.2 V / 1.5 V	1.8	1.8	1.8	1.8	1.8	1.8	μA
$V_{CCI} / V_{JTAG} = 1.8\text{ V}$ (per bank) Typical (25°C)	1.2 V / 1.5 V	1.9	1.9	1.9	1.9	1.9	1.9	μA
$V_{CCI} / V_{JTAG} = 2.5\text{ V}$ (per bank) Typical (25°C)	1.2 V / 1.5 V	2.2	2.2	2.2	2.2	2.2	2.2	μA
$V_{CCI} / V_{JTAG} = 3.3\text{ V}$ (per bank) Typical (25°C)	1.2 V / 1.5 V	2.5	2.5	2.5	2.5	2.5	2.5	μA

Notes:

1. To calculate total device I_{DD} , multiply the number of banks used by I_{CCI} and add I_{CCA} contribution.
2. Includes V_{CC}, V_{CCPLL} , and V_{PUMP} currents.
3. Per V_{CCI} or V_{JTAG} bank

Power per I/O Pin

Table 2-12 • Summary of I/O Input Buffer Power (per pin) – Default I/O Software Settings
Applicable to IGLOO nano I/O Banks

	V_{CCI} (V)	Dynamic Power P_{AC9} (μ W/MHz) ¹
Single-Ended		
3.3 V LVTTTL / 3.3 V LVCMOS	3.3	16.26
3.3 V LVTTTL / 3.3 V LVCMOS – Schmitt Trigger	3.3	18.95
2.5 V LVCMOS	2.5	4.59
2.5 V LVCMOS – Schmitt Trigger	2.5	6.01
1.8 V LVCMOS	1.8	1.61
1.8 V LVCMOS – Schmitt Trigger	1.8	1.70
1.5 V LVCMOS (JESD8-11)	1.5	0.96
1.5 V LVCMOS (JESD8-11) – Schmitt Trigger	1.5	0.90
1.2 V LVCMOS ²	1.2	0.55
1.2 V LVCMOS ² – Schmitt Trigger	1.2	0.47

Notes:

1. P_{AC9} is the total dynamic power measured on V_{CCI} .
2. Applicable to IGLOO nano V2 devices operating at $V_{CCI} \geq V_{CC}$.

Table 2-13 • Summary of I/O Output Buffer Power (per pin) – Default I/O Software Settings¹
Applicable to IGLOO nano I/O Banks

	C_{LOAD} (pF)	V_{CCI} (V)	Dynamic Power P_{AC10} (μ W/MHz) ²
Single-Ended			
3.3 V LVTTTL / 3.3 V LVCMOS	5	3.3	107.98
2.5 V LVCMOS	5	2.5	61.24
1.8 V LVCMOS	5	1.8	31.28
1.5 V LVCMOS (JESD8-11)	5	1.5	21.50
1.2 V LVCMOS ³	5	1.2	21.05

Notes:

1. Dynamic power consumption is given for standard load and software default drive strength and output slew.
2. P_{AC10} is the total dynamic power measured on V_{CCI} .
3. Applicable for IGLOO nano V2 devices operating at $V_{CCI} \geq V_{CC}$.

Power Consumption of Various Internal Resources

Table 2-14 • Different Components Contributing to Dynamic Power Consumption in IGLOO nano Devices For IGLOO nano V2 or V5 Devices, 1.5 V Core Supply Voltage

Parameter	Definition	Device Specific Dynamic Power ($\mu\text{W}/\text{MHz}$)					
		AGLN250	AGLN125	AGLN060	AGLN020	AGLN015	AGLN010
P _{AC1}	Clock contribution of a Global Rib	11.03	11.03	9.3	9.3	9.3	9.3
P _{AC2}	Clock contribution of a Global Spine	1.58	0.81	0.81	0.41	0.41	0.41
P _{AC3}	Clock contribution of a VersaTile row	0.81					
P _{AC4}	Clock contribution of a VersaTile used as a sequential module	0.11					
P _{AC5}	First contribution of a VersaTile used as a sequential module	0.057					
P _{AC6}	Second contribution of a VersaTile used as a sequential module	0.207					
P _{AC7}	Contribution of a VersaTile used as a combinatorial module	0.17					
P _{AC8}	Average contribution of a routing net	0.7					
P _{AC9}	Contribution of an I/O input pin (standard-dependent)	See Table 2-12 on page 2-9.					
P _{AC10}	Contribution of an I/O output pin (standard-dependent)	See Table 2-13.					
P _{AC11}	Average contribution of a RAM block during a read operation	25.00			N/A		
P _{AC12}	Average contribution of a RAM block during a write operation	30.00			N/A		
P _{AC13}	Dynamic contribution for PLL	2.70			N/A		

Table 2-15 • Different Components Contributing to the Static Power Consumption in IGLOO nano Devices For IGLOO nano V2 or V5 Devices, 1.5 V Core Supply Voltage

Parameter	Definition	Device -Specific Static Power (mW)					
		AGLN250	AGLN125	AGLN060	AGLN020	AGLN015	AGLN010
P _{DC1}	Array static power in Active mode	See Table 2-11 on page 2-8					
P _{DC2}	Array static power in Static (Idle) mode	See Table 2-11 on page 2-8					
P _{DC3}	Array static power in Flash*Freeze mode	See Table 2-8 on page 2-7					
P _{DC4} ²	Static PLL contribution	1.84			N/A		
P _{DC5}	Bank quiescent power (V _{CCI} -dependent)	See Table 2-11 on page 2-8					

Notes:

1. For a different output load, drive strength, or slew rate, Actel recommends using the Actel power spreadsheet calculator or the SmartPower tool in Actel Libero® Integrated Design Environment (IDE).
2. Minimum contribution of the PLL when running at lowest frequency.



Table 2-16 • Different Components Contributing to Dynamic Power Consumption in IGLOO nano Devices For IGLOO nano V2 Devices, 1.2 V Core Supply Voltage

Parameter	Definition	Device-Specific Dynamic Power ($\mu\text{W}/\text{MHz}$)					
		AGLN250	AGLN125	AGLN060	AGLN020	AGLN015	AGLN010
P _{AC1}	Clock contribution of a Global Rib	7.07	7.07	5.96	5.96	5.96	5.96
P _{AC2}	Clock contribution of a Global Spine	1.01	0.52	0.52	0.26	0.26	0.26
P _{AC3}	Clock contribution of a VersaTile row	0.52					
P _{AC4}	Clock contribution of a VersaTile used as a sequential module	0.07					
P _{AC5}	First contribution of a VersaTile used as a sequential module	0.045					
P _{AC6}	Second contribution of a VersaTile used as a sequential module	0.186					
P _{AC7}	Contribution of a VersaTile used as a combinatorial module	0.11					
P _{AC8}	Average contribution of a routing net	0.45					
P _{AC9}	Contribution of an I/O input pin (standard-dependent)	See Table 2-12 on page 2-9					
P _{AC10}	Contribution of an I/O output pin (standard-dependent)	See Table 2-13 on page 2-9					
P _{AC11}	Average contribution of a RAM block during a read operation	25.00			N/A		
P _{AC12}	Average contribution of a RAM block during a write operation	30.00			N/A		
P _{AC13}	Dynamic contribution for PLL	2.10			N/A		

Table 2-17 • Different Components Contributing to the Static Power Consumption in IGLOO nano Devices For IGLOO nano V2 Devices, 1.2 V Core Supply Voltage

Parameter	Definition	Device-Specific Static Power (mW)					
		AGLN250	AGLN125	AGLN060	AGLN020	AGLN015	AGLN010
P _{DC1}	Array static power in Active mode	See Table 2-11 on page 2-8					
P _{DC2}	Array static power in Static (Idle) mode	See Table 2-11 on page 2-8					
P _{DC3}	Array static power in Flash*Freeze mode	See Table 2-8 on page 2-7					
P _{DC4} ²	Static PLL contribution	0.90			N/A		
P _{DC5}	Bank quiescent power (V _{CCI} -dependent)	See Table 2-11 on page 2-8					

Notes:

1. For a different output load, drive strength, or slew rate, Actel recommends using the Actel power spreadsheet calculator or the SmartPower tool in Actel Libero IDE.
2. Minimum contribution of the PLL when running at lowest frequency.

Power Calculation Methodology

This section describes a simplified method to estimate power consumption of an application. For more accurate and detailed power estimations, use the SmartPower tool in Actel Libero IDE software.

The power calculation methodology described below uses the following variables:

- The number of PLLs as well as the number and the frequency of each output clock generated
- The number of combinatorial and sequential cells used in the design
- The internal clock frequencies
- The number and the standard of I/O pins used in the design
- The number of RAM blocks used in the design
- Toggle rates of I/O pins as well as VersaTiles—guidelines are provided in [Table 2-18 on page 2-14](#).
- Enable rates of output buffers—guidelines are provided for typical applications in [Table 2-19 on page 2-14](#).
- Read rate and write rate to the memory—guidelines are provided for typical applications in [Table 2-19 on page 2-14](#). The calculation should be repeated for each clock domain defined in the design.

Methodology

Total Power Consumption— P_{TOTAL}

$$P_{TOTAL} = P_{STAT} + P_{DYN}$$

P_{STAT} is the total static power consumption.

P_{DYN} is the total dynamic power consumption.

Total Static Power Consumption— P_{STAT}

$$P_{STAT} = (P_{DC1} \text{ or } P_{DC2} \text{ or } P_{DC3}) + N_{BANKS} * P_{DC5}$$

N_{BANKS} is the number of I/O banks powered in the design.

Total Dynamic Power Consumption— P_{DYN}

$$P_{DYN} = P_{CLOCK} + P_{S-CELL} + P_{C-CELL} + P_{NET} + P_{INPUTS} + P_{OUTPUTS} + P_{MEMORY} + P_{PLL}$$

Global Clock Contribution— P_{CLOCK}

$$P_{CLOCK} = (P_{AC1} + N_{SPINE} * P_{AC2} + N_{ROW} * P_{AC3} + N_{S-CELL} * P_{AC4}) * F_{CLK}$$

N_{SPINE} is the number of global spines used in the user design—guidelines are provided in [Table 2-18 on page 2-14](#).

N_{ROW} is the number of VersaTile rows used in the design—guidelines are provided in [Table 2-18 on page 2-14](#).

F_{CLK} is the global clock signal frequency.

N_{S-CELL} is the number of VersaTiles used as sequential modules in the design.

P_{AC1} , P_{AC2} , P_{AC3} , and P_{AC4} are device-dependent.

Sequential Cells Contribution— P_{S-CELL}

$$P_{S-CELL} = N_{S-CELL} * (P_{AC5} + \alpha_1 / 2 * P_{AC6}) * F_{CLK}$$

N_{S-CELL} is the number of VersaTiles used as sequential modules in the design. When a multi-tile sequential cell is used, it should be accounted for as 1.

α_1 is the toggle rate of VersaTile outputs—guidelines are provided in [Table 2-18 on page 2-14](#).

F_{CLK} is the global clock signal frequency.

Combinatorial Cells Contribution— P_{C-CELL}

$$P_{C-CELL} = N_{C-CELL} * \alpha_1 / 2 * P_{AC7} * F_{CLK}$$

N_{C-CELL} is the number of VersaTiles used as combinatorial modules in the design.

α_1 is the toggle rate of VersaTile outputs—guidelines are provided in [Table 2-18 on page 2-14](#).

F_{CLK} is the global clock signal frequency.

Routing Net Contribution— P_{NET}

$$P_{NET} = (N_{S-CELL} + N_{C-CELL}) * \alpha_1 / 2 * P_{AC8} * F_{CLK}$$

N_{S-CELL} is the number of VersaTiles used as sequential modules in the design.

N_{C-CELL} is the number of VersaTiles used as combinatorial modules in the design.

α_1 is the toggle rate of VersaTile outputs—guidelines are provided in [Table 2-18 on page 2-14](#).

F_{CLK} is the global clock signal frequency.

I/O Input Buffer Contribution— P_{INPUTS}

$$P_{INPUTS} = N_{INPUTS} * \alpha_2 / 2 * P_{AC9} * F_{CLK}$$

N_{INPUTS} is the number of I/O input buffers used in the design.

α_2 is the I/O buffer toggle rate—guidelines are provided in [Table 2-18 on page 2-14](#).

F_{CLK} is the global clock signal frequency.

I/O Output Buffer Contribution— $P_{OUTPUTS}$

$$P_{OUTPUTS} = N_{OUTPUTS} * \alpha_2 / 2 * \beta_1 * P_{AC10} * F_{CLK}$$

$N_{OUTPUTS}$ is the number of I/O output buffers used in the design.

α_2 is the I/O buffer toggle rate—guidelines are provided in [Table 2-18 on page 2-14](#).

β_1 is the I/O buffer enable rate—guidelines are provided in [Table 2-19 on page 2-14](#).

F_{CLK} is the global clock signal frequency.

RAM Contribution— P_{MEMORY}

$$P_{MEMORY} = P_{AC11} * N_{BLOCKS} * F_{READ-CLOCK} * \beta_2 + P_{AC12} * N_{BLOCK} * F_{WRITE-CLOCK} * \beta_3$$

N_{BLOCKS} is the number of RAM blocks used in the design.

$F_{READ-CLOCK}$ is the memory read clock frequency.

β_2 is the RAM enable rate for read operations.

$F_{WRITE-CLOCK}$ is the memory write clock frequency.

β_3 is the RAM enable rate for write operations—guidelines are provided in [Table 2-19 on page 2-14](#).

PLL Contribution— P_{PLL}

$$P_{PLL} = P_{DC4} + P_{AC13} * F_{CLKOUT}$$

F_{CLKOUT} is the output clock frequency.¹

1. If a PLL is used to generate more than one output clock, include each output clock in the formula by adding its corresponding contribution ($P_{AC13} * F_{CLKOUT}$ product) to the total PLL contribution.

Guidelines

Toggle Rate Definition

A toggle rate defines the frequency of a net or logic element relative to a clock. It is a percentage. If the toggle rate of a net is 100%, this means that this net switches at half the clock frequency. Below are some examples:

- The average toggle rate of a shift register is 100% because all flip-flop outputs toggle at half of the clock frequency.
- The average toggle rate of an 8-bit counter is 25%:
 - Bit 0 (LSB) = 100%
 - Bit 1 = 50%
 - Bit 2 = 25%
 - ...
 - Bit 7 (MSB) = 0.78125%
 - Average toggle rate = $(100\% + 50\% + 25\% + 12.5\% + \dots + 0.78125\%) / 8$

Enable Rate Definition

Output enable rate is the average percentage of time during which tristate outputs are enabled. When nontristate output buffers are used, the enable rate should be 100%.

Table 2-18 • Toggle Rate Guidelines Recommended for Power Calculation

Component	Definition	Guideline
α_1	Toggle rate of VersaTile outputs	10%
α_2	I/O buffer toggle rate	10%

Table 2-19 • Enable Rate Guidelines Recommended for Power Calculation

Component	Definition	Guideline
β_1	I/O output buffer enable rate	100%
β_2	RAM enable rate for read operations	12.5%
β_3	RAM enable rate for write operations	12.5%

User I/O Characteristics

Timing Model

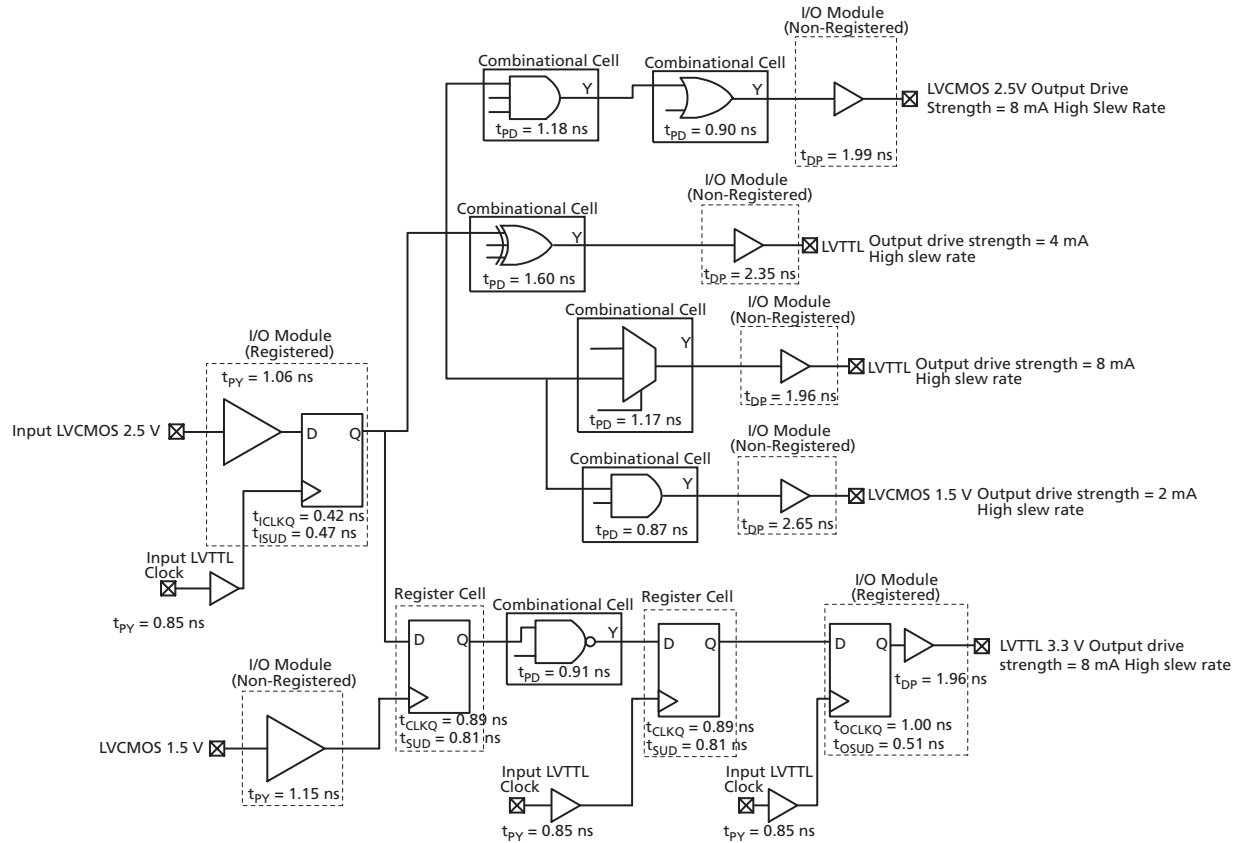

Figure 2-3 • Timing Model

Operating Conditions: STD Speed, Commercial Temperature Range ($T_J = 70^\circ\text{C}$), Worst-Case $V_{CC} = 1.425$ V, for DC 1.5 V Core Voltage, Applicable to V2 and V5 Devices

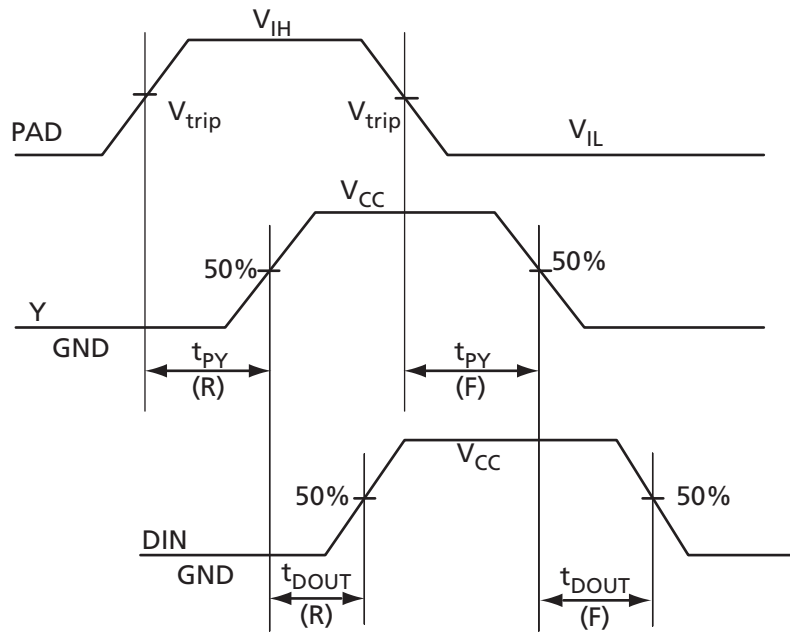
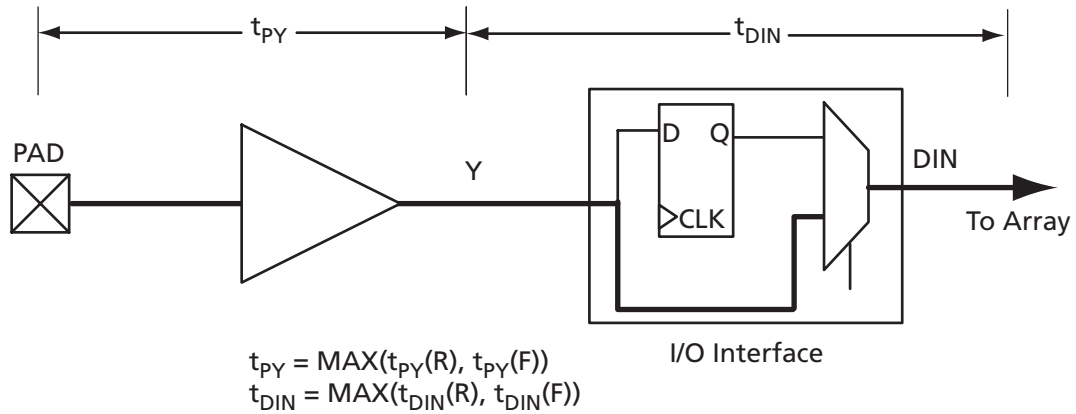

Figure 2-4 • Input Buffer Timing Model and Delays (example)

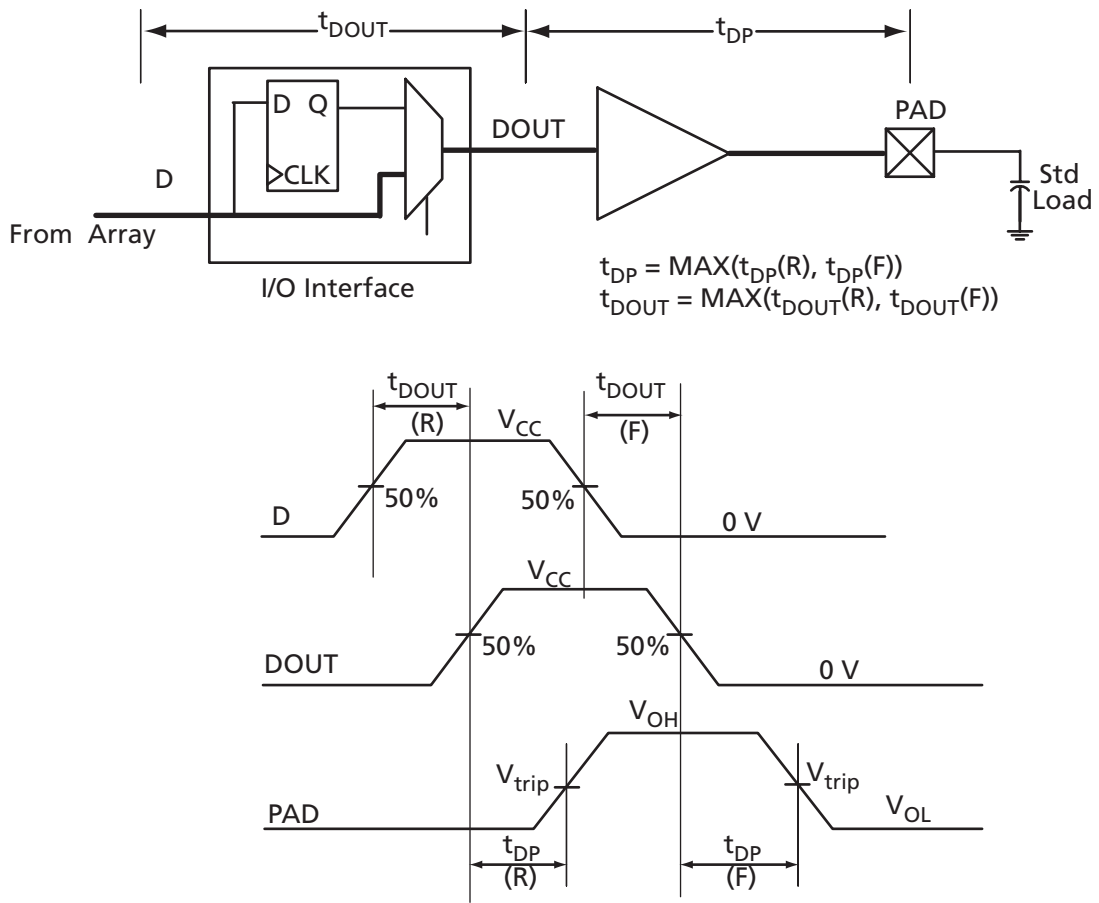

Figure 2-5 • Output Buffer Model and Delays (example)

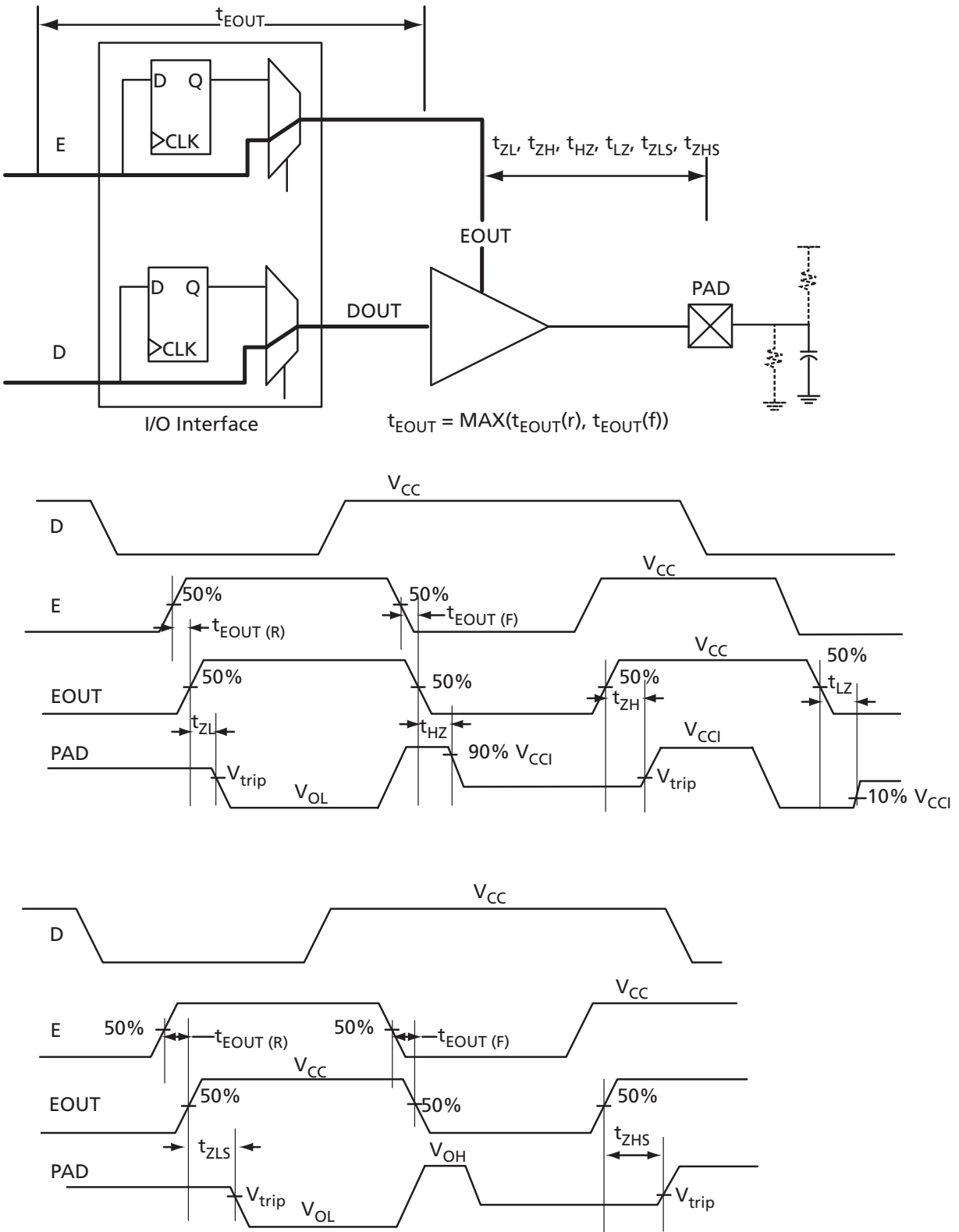

Figure 2-6 • Tristate Output Buffer Timing Model and Delays (example)

Overview of I/O Performance

Summary of I/O DC Input and Output Levels – Default I/O Software Settings

**Table 2-20 • Summary of Maximum and Minimum DC Input and Output Levels
Applicable to Commercial and Industrial Conditions—Software Default Settings**

I/O Standard	Drive Strength	Slew Rate	V _{IL}		V _{IH}		V _{OL}	V _{OH}	I _{OL} ¹	I _{OH} ¹
			Min, V	Max, V	Min, V	Max, V	Max, V	Min, V	mA	mA
3.3 V LVTTTL / 3.3 V LVCMOS	8 mA	High	-0.3	0.8	2	3.6	0.4	2.4	8	8
3.3 V Wide Range	Any ²	High	-0.3	0.8	2	3.6	0.2	V _{CC1} - 0.2	100 μA	100 μA
2.5 V LVCMOS	8 mA	High	-0.3	0.7	1.7	3.6	0.7	1.7	8	8
1.8 V LVCMOS	4 mA	High	-0.3	0.35 * V _{CC1}	0.65 * V _{CC1}	3.6	0.45	V _{CC1} - 0.45	4	4
1.5 V LVCMOS	2 mA	High	-0.3	0.35 * V _{CC1}	0.65 * V _{CC1}	3.6	0.25 * V _{CC1}	0.75 * V _{CC1}	2	2
1.2 V LVCMOS ³	1 mA	High	-0.3	0.35 * V _{CC1}	0.65 * V _{CC1}	3.6	0.25 * V _{CC1}	0.75 * V _{CC1}	1	1
1.2 V LVCMOS Wide Range ³	Any ⁴	High	-0.3	0.3 * V _{CC1}	0.7 * V _{CC1}	3.6	0.1	V _{CC1} - 0.1	100 μA	100 μA

Notes:

1. Currents are measured at 85°C junction temperature.
2. All LVCMOS 3.3 V software macros support LVCMOS 3.3 V wide range, as specified in the JESD8-B specification.
3. Applicable to IGLOO nano V2 devices operating at V_{CC1} ≥ V_{CC}.
4. All LVCMOS 1.2 V software macros support LVCMOS 1.2 V wide range, as specified in the JESD8-12 specification.

**Table 2-21 • Summary of Maximum and Minimum DC Input Levels
Applicable to Commercial and Industrial Conditions**

DC I/O Standards	Commercial ¹		Industrial ²	
	I _{IL} ³	I _{IH} ⁴	I _{IL} ³	I _{IH} ⁴
	μA	μA	μA	μA
3.3 V LVTTTL / 3.3 V LVCMOS	10	10	15	15
3.3 V LVCOMS Wide Range	10	10	15	15
2.5 V LVCMOS	10	10	15	15
1.8 V LVCMOS	10	10	15	15
1.5 V LVCMOS	10	10	15	15
1.2 V LVCMOS ⁵	10	10	15	15
1.2 V LVCMOS Wide Range ⁵	10	10	15	15

Notes:

1. Commercial range (-20°C < T_A < 70°C)
2. Industrial range (-40°C < T_A < 85°C)
3. I_{IH} is the input leakage current per I/O pin over recommended operating conditions, where V_{IH} < V_{IN} < V_{CC1}. Input current is larger when operating outside recommended ranges.
4. I_{IL} is the input leakage current per I/O pin over recommended operating conditions, where -0.3 V < V_{IN} < V_{IL}.
5. Applicable to IGLOO nano V2 devices operating at V_{CC1} ≥ V_{CC}.

Summary of I/O Timing Characteristics – Default I/O Software Settings

Table 2-22 • Summary of AC Measuring Points

Standard	Measuring Trip Point (V_{trip})
3.3 V LVTTTL / 3.3 V LVCMOS	1.4 V
3.3 V LVCMOS Wide Range	1.4 V
2.5 V LVCMOS	1.2 V
1.8 V LVCMOS	0.90 V
1.5 V LVCMOS	0.75 V
1.2 V LVCMOS	0.60 V
1.2 V LVCMOS Wide Range	0.60 V

Table 2-23 • I/O AC Parameter Definitions

Parameter	Parameter Definition
t_{DP}	Data to Pad delay through the Output Buffer
t_{PY}	Pad to Data delay through the Input Buffer
t_{DOUT}	Data to Output Buffer delay through the I/O interface
t_{EOUT}	Enable to Output Buffer Tristate Control delay through the I/O interface
t_{DIN}	Input Buffer to Data delay through the I/O interface
t_{HZ}	Enable to Pad delay through the Output Buffer—HIGH to Z
t_{ZH}	Enable to Pad delay through the Output Buffer—Z to HIGH
t_{LZ}	Enable to Pad delay through the Output Buffer—LOW to Z
t_{ZL}	Enable to Pad delay through the Output Buffer—Z to LOW
t_{ZHS}	Enable to Pad delay through the Output Buffer with delayed enable—Z to HIGH
t_{ZLS}	Enable to Pad delay through the Output Buffer with delayed enable—Z to LOW

Applies to IGLoo nano at 1.5 V Core Operating Conditions
Table 2-24 • Summary of I/O Timing Characteristics—Software Default Settings
 STD Speed Grade, Commercial-Case Conditions: $T_J = 70^\circ\text{C}$, Worst-Case $V_{CC} = 1.425\text{ V}$,
 Worst-Case $V_{CCI} = 3.0\text{ V}$

I/O Standard	Drive Strength (mA)	Slew Rate	Capacitive Load (pF)	t_{DOUT}	t_{DP}	t_{DIN}	t_{PY}	t_{PYS}	t_{EOUT}	t_{ZL}	t_{ZH}	t_{LZ}	t_{HZ}	Units
3.3 V LVTTTL / 3.3 V LVCMOS	8 mA	High	5 pF	0.97	1.96	0.19	0.85	1.14	0.66	1.73	1.32	2.04	2.38	ns
3.3 V LVCMOS Wide Range	Any ¹	High	5 pF	TBD	TBD	TBD	TBD	TBD	TBD	TBD	TBD	TBD	TBD	TBD
2.5 V LVCMOS	8 mA	High	5 pF	0.97	1.99	0.19	1.06	1.22	0.66	1.76	1.42	2.04	2.25	ns
1.8 V LVCMOS	4 mA	High	5 pF	0.97	2.30	0.19	0.99	1.43	0.66	2.01	1.64	2.08	2.15	ns
1.5 V LVCMOS	2 mA	High	5 pF	0.97	2.65	0.19	1.15	1.62	0.66	2.31	1.85	2.13	2.11	ns

Notes:

1. All LVCMOS 3.3 V software macros support LVCMOS 3.3 V wide range, as specified in the JESD8-B specification.
2. For specific junction temperature and voltage supply levels, refer to [Table 2-6 on page 2-6](#) for derating values.

Applies to IGLoo nano at 1.2 V Core Operating Conditions
Table 2-25 • Summary of I/O Timing Characteristics—Software Default Settings
 STD Speed Grade, Commercial-Case Conditions: $T_J = 70^\circ\text{C}$, Worst-Case $V_{CC} = 1.14\text{ V}$,
 Worst-Case $V_{CCI} = 3.0\text{ V}$

I/O Standard	Drive Strength (mA)	Slew Rate	Capacitive Load (pF)	t_{DOUT}	t_{DP}	t_{DIN}	t_{PY}	t_{PYS}	t_{EOUT}	t_{ZL}	t_{ZH}	t_{LZ}	t_{HZ}	Units
3.3 V LVTTTL / 3.3 V LVCMOS	8 mA	High	5 pF	1.55	2.81	0.26	0.99	1.14	1.10	2.53	2.01	2.48	3.10	ns
3.3 V LVCMOS Wide Range	Any ¹	High	5 pF	TBD	TBD	TBD	TBD	TBD	TBD	TBD	TBD	TBD	TBD	ns
2.5 V LVCMOS	8 mA	High	5 pF	1.55	2.82	0.26	1.20	1.22	1.10	2.53	2.15	2.46	2.93	ns
1.8 V LVCMOS	4 mA	High	5 pF	1.55	3.11	0.26	1.12	1.43	1.10	2.76	2.46	2.49	2.75	ns
1.5 V LVCMOS	2 mA	High	5 pF	1.55	3.50	0.26	1.26	1.62	1.10	3.09	2.76	2.53	2.67	ns
1.2 V LVCMOS	1 mA	High	5 pF	1.55	4.47	0.26	1.56	1.66	1.10	3.56	3.18	3.00	3.25	ns
1.2 V LVCMOS Wide Range	100 μA	High	5 pF	TBD	TBD	TBD	TBD	TBD	TBD	TBD	TBD	TBD	TBD	ns

Notes:

1. All LVCMOS 3.3 V software macros support LVCMOS 3.3 V wide range, as specified in the JESD8-B specification.
2. For specific junction temperature and voltage supply levels, refer to [Table 2-6 on page 2-6](#) for derating values.

Detailed I/O DC Characteristics

Table 2-26 • Input Capacitance

Symbol	Definition	Conditions	Min.	Max.	Units
C_{IN}	Input capacitance	$V_{IN} = 0, f = 1.0 \text{ MHz}$		8	pF
C_{INCLK}	Input capacitance on the clock pin	$V_{IN} = 0, f = 1.0 \text{ MHz}$		8	pF

Table 2-27 • I/O Output Buffer Maximum Resistances ¹

Standard	Drive Strength	$R_{PULL-DOWN}$ (Ω) ²	$R_{PULL-UP}$ (Ω) ³
3.3 V LVTTTL / 3.3V LVCMOS	2 mA	100	300
	4 mA	100	300
	6 mA	50	150
	8 mA	50	150
3.3 V LVCMOS Wide Range	100 μ A	TBD	TBD
2.5 V LVCMOS	2 mA	100	200
	4 mA	100	200
	6 mA	50	100
	8 mA	50	100
1.8 V LVCMOS	2 mA	200	225
	4 mA	100	112
1.5 V LVCMOS	2 mA	200	224
1.2 V LVCMOS ⁴	2 mA	TBD	TBD
1.2 V LVCMOS Wide Range ⁴	100 μ A	TBD	TBD

Notes:

1. These maximum values are provided for informational reasons only. Minimum output buffer resistance values depend on V_{CC} , drive strength selection, temperature, and process. For board design considerations and detailed output buffer resistances, use the corresponding IBIS models located on the Actel website at <http://www.actel.com/download/libis/default.aspx>.
2. $R_{(PULL-DOWN-MAX)} = (V_{OLspec}) / I_{OLspec}$
3. $R_{(PULL-UP-MAX)} = (V_{CCImax} - V_{OHspec}) / I_{OHspec}$
4. Applicable to IGLOO nano V2 devices operating at $V_{CCI} \geq V_{CC}$.

Table 2-28 • I/O Weak Pull-Up/Pull-Down Resistances
 Minimum and Maximum Weak Pull-Up/Pull-Down Resistance Values

V _{CC1}	R _(WEAK PULL-UP) ¹ (Ω)		R _(WEAK PULL-DOWN) ² (Ω)	
	Min.	Max.	Min.	Max.
3.3 V	10 k	45 k	10 k	45 k
2.5 V	11 k	55 k	12 k	74 k
1.8 V	18 k	70 k	17 k	110 k
1.5 V	19 k	90 k	19 k	140 k
1.2 V	25 k	110 k	25 k	150 k

Notes:

1. $R_{(WEAK\ PULL-UP-MAX)} = (V_{OLspec}) / I_{(WEAK\ PULL-UP-MIN)}$
2. $R_{(WEAK\ PULL-UP-MAX)} = (V_{CCImax} - V_{OHspec}) / I_{(WEAK\ PULL-UP-MIN)}$

Table 2-29 • I/O Short Currents I_{OSH}/I_{OSL}

	Drive Strength	I _{OSL} (mA)*	I _{OSH} (mA)*
3.3 V LVTTTL / 3.3 V LVCMOS	2 mA	25	27
	4 mA	25	27
	6 mA	51	54
	8 mA	51	54
3.3 V LVCMOS Wide Range	100 μA	TBD	TBD
2.5 V LVCMOS	2 mA	16	18
	4 mA	16	18
	6 mA	32	37
	8 mA	32	37
1.8 V LVCMOS	2 mA	9	11
	4 mA	17	22
1.5 V LVCMOS	2 mA	13	16
1.2 V LVCMOS	1 mA	TBD	TBD
1.2 V LVCMOS Wide Range	100 μA	TBD	TBD

 * T_J = 100°C

The length of time an I/O can withstand I_{OSH}/I_{OSL} events depends on the junction temperature. The reliability data below is based on a 3.3 V, 8 mA I/O setting, which is the worst case for this type of analysis.

For example, at 110°C, the short current condition would have to be sustained for more than three months to cause a reliability concern. The I/O design does not contain any short circuit protection, but such protection would only be needed in extremely prolonged stress conditions.

Table 2-30 • Duration of Short Circuit Event before Failure

Temperature	Time before Failure
-40°C	> 20 years
-20°C	> 20 years
0°C	> 20 years
25°C	> 20 years
70°C	5 years
85°C	2 years
100°C	6 months
110°C	3 months

Table 2-31 • Schmitt Trigger Input Hysteresis Hysteresis Voltage Value (Typ.) for Schmitt Mode Input Buffers

Input Buffer Configuration	Hysteresis Value (typ.)
3.3 V LVTTTL / LVCMOS (Schmitt trigger mode)	240 mV
2.5 V LVCMOS (Schmitt trigger mode)	140 mV
1.8 V LVCMOS (Schmitt trigger mode)	80 mV
1.5 V LVCMOS (Schmitt trigger mode)	60 mV
1.2 V LVCMOS (Schmitt trigger mode)	40 mV

Table 2-32 • I/O Input Rise Time, Fall Time, and Related I/O Reliability

Input Buffer	Input Rise/Fall Time (min.)	Input Rise/Fall Time (max.)	Reliability
LVTTTL/LVCMOS (Schmitt trigger disabled)	No requirement	10 ns *	20 years (100°C)
LVTTTL/LVCMOS (Schmitt trigger enabled)	No requirement	No requirement, but input noise voltage cannot exceed Schmitt hysteresis.	20 years (100°C)

* The maximum input rise/fall time is related to the noise induced into the input buffer trace. If the noise is low, then the rise time and fall time of input buffers can be increased beyond the maximum value. The longer the rise/fall times, the more susceptible the input signal is to the board noise. Actel recommends signal integrity evaluation/characterization of the system to ensure that there is no excessive noise coupling into input signals.



Single-Ended I/O Characteristics

3.3 V LVTTTL / 3.3 V LVCMOS

Low-Voltage Transistor–Transistor Logic (LVTTTL) is a general-purpose standard (EIA/JESD) for 3.3 V applications. It uses an LVTTTL input buffer and push-pull output buffer.

Table 2-33 • Minimum and Maximum DC Input and Output Levels

3.3 V LVTTTL / 3.3 V LVCMOS	V_{IL}		V_{IH}		V_{OL}	V_{OH}	I_{OL}	I_{OH}	I_{OSL}	I_{OSH}	I_{IL}^1	I_{IH}^2
	Min., V	Max., V	Min., V	Max., V	Max., V	Min., V	mA	mA	Max., mA ³	Max., mA ³	μA^4	μA^4
2 mA	-0.3	0.8	2	3.6	0.4	2.4	2	2	25	27	10	10
4 mA	-0.3	0.8	2	3.6	0.4	2.4	4	4	25	27	10	10
6 mA	-0.3	0.8	2	3.6	0.4	2.4	6	6	51	54	10	10
8 mA	-0.3	0.8	2	3.6	0.4	2.4	8	8	51	54	10	10

Notes:

1. I_{IL} is the input leakage current per I/O pin over recommended operating conditions where $-0.3 < V_{IN} < V_{IL}$.
2. I_{IH} is the input leakage current per I/O pin over recommended operating conditions where $V_{IH} < V_{IN} < V_{CCI}$. Input current is larger when operating outside recommended ranges.
3. Currents are measured at high temperature (100°C junction temperature) and maximum voltage.
4. Currents are measured at 85°C junction temperature.
5. Software default selection highlighted in gray.

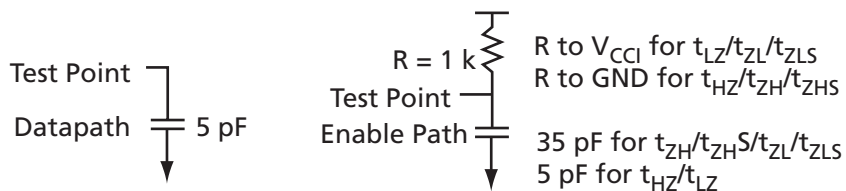

Figure 2-7 • AC Loading

Table 2-34 • 3.3 V LVTTTL/LVCMOS AC Waveforms, Measuring Points, and Capacitive Loads

Input LOW (V)	Input HIGH (V)	Measuring Point* (V)	C _{LOAD} (pF)
0	3.3	1.4	5

* Measuring point = V_{trip} . See Table 2-22 on page 2-20 for a complete table of trip points.

Timing Characteristics

Applies to 1.5 V DC Core Voltage

Table 2-35 • 3.3 V LVTTTL / 3.3 V LVCMOS Low Slew – Applies to 1.5 V DC Core Voltage
Commercial-Case Conditions: $T_J = 70^\circ\text{C}$, Worst-Case $V_{CC} = 1.425\text{ V}$, Worst-Case $V_{CCI} = 3.0\text{ V}$

Drive Strength	Speed Grade	t_{DOUT}	t_{DP}	t_{DIN}	t_{PY}	t_{PYS}	t_{EOUT}	t_{ZL}	t_{ZH}	t_{LZ}	t_{HZ}	Units
2 mA	STD	0.97	3.94	0.19	0.85	1.14	0.66	3.39	2.95	1.82	1.87	ns
4 mA	STD	0.97	3.94	0.19	0.85	1.14	0.66	3.39	2.95	1.82	1.87	ns
6 mA	STD	0.97	3.20	0.19	0.85	1.14	0.66	2.88	2.65	2.04	2.27	ns
8 mA	STD	0.97	3.20	0.19	0.85	1.14	0.66	2.88	2.65	2.04	2.27	ns

Note: For specific junction temperature and voltage supply levels, refer to [Table 2-6 on page 2-6](#) for derating values.

Table 2-36 • 3.3 V LVTTTL / 3.3 V LVCMOS High Slew – Applies to 1.5 V DC Core Voltage
Commercial-Case Conditions: $T_J = 70^\circ\text{C}$, Worst-Case $V_{CC} = 1.425\text{ V}$, Worst-Case $V_{CCI} = 3.0\text{ V}$

Drive Strength	Speed Grade	t_{DOUT}	t_{DP}	t_{DIN}	t_{PY}	t_{PYS}	t_{EOUT}	t_{ZL}	t_{ZH}	t_{LZ}	t_{HZ}	Units
2 mA	STD	0.97	2.35	0.19	0.85	1.14	0.66	1.88	1.43	1.81	1.98	ns
4 mA	STD	0.97	2.35	0.19	0.85	1.14	0.66	1.88	1.43	1.81	1.98	ns
6 mA	STD	0.97	1.96	0.19	0.85	1.14	0.66	1.73	1.32	2.04	2.38	ns
8 mA	STD	0.97	1.96	0.19	0.85	1.14	0.66	1.73	1.32	2.04	2.38	ns

Notes:

1. Software default selection highlighted in gray.
2. For specific junction temperature and voltage supply levels, refer to [Table 2-6 on page 2-6](#) for derating values.

Applies to 1.2 V DC Core Voltage**Table 2-37 • 3.3 V LVTTTL / 3.3 V LVCMOS Low Slew – Applies to 1.2 V DC Core Voltage**
Commercial-Case Conditions: $T_J = 70^\circ\text{C}$, Worst-Case $V_{CC} = 1.14\text{ V}$, Worst-Case $V_{CCI} = 3.0\text{ V}$

Drive Strength	Speed Grade	t_{DOUT}	t_{DP}	t_{DIN}	t_{PY}	t_{PYS}	t_{EOUT}	t_{ZL}	t_{ZH}	t_{LZ}	t_{HZ}	Units
2 mA	STD	1.55	5.23	0.26	0.99	1.14	1.10	4.56	3.93	2.25	2.56	ns
4 mA	STD	1.55	5.23	0.26	0.99	1.14	1.10	4.56	3.93	2.25	2.56	ns
6 mA	STD	1.55	4.21	0.26	0.99	1.14	1.10	3.81	3.42	2.48	2.97	ns
8 mA	STD	1.55	4.21	0.26	0.99	1.14	1.10	3.81	3.42	2.48	2.97	ns

Note: For specific junction temperature and voltage supply levels, refer to [Table 2-6 on page 2-6](#) for derating values.

Table 2-38 • 3.3 V LVTTTL / 3.3 V LVCMOS High Slew – Applies to 1.2 V DC Core Voltage
Commercial-Case Conditions: $T_J = 70^\circ\text{C}$, Worst-Case $V_{CC} = 1.14\text{ V}$, Worst-Case $V_{CCI} = 3.0\text{ V}$

Drive Strength	Speed Grade	t_{DOUT}	t_{DP}	t_{DIN}	t_{PY}	t_{PYS}	t_{EOUT}	t_{ZL}	t_{ZH}	t_{LZ}	t_{HZ}	Units
2 mA	STD	1.55	3.49	0.26	0.99	1.14	1.10	2.91	2.33	2.24	2.68	ns
4 mA	STD	1.55	3.49	0.26	0.99	1.14	1.10	2.91	2.33	2.24	2.68	ns
6 mA	STD	1.55	2.81	0.26	0.99	1.14	1.10	2.53	2.01	2.48	3.10	ns
8 mA	STD	1.55	2.81	0.26	0.99	1.14	1.10	2.53	2.01	2.48	3.10	ns

Notes:

1. Software default selection highlighted in gray.
2. For specific junction temperature and voltage supply levels, refer to [Table 2-6 on page 2-6](#) for derating values.

3.3 V LVCMOS Wide Range

Table 2-39 • Minimum and Maximum DC Input and Output Levels for LVCMOS 3.3 V Wide Range

3.3 V LVCMOS Wide Range	V_{IL}		V_{IH}		V_{OL}	V_{OH}	I_{OL}	I_{OH}	I_{IL}^1	I_{IH}^2
	Min., V	Max., V	Min., V	Max., V	Max., V	Min., V	μA	μA	μA^3	μA^3
All ⁴	-0.3	0.8	2	3.6	0.2	$V_{DD} - 0.2$	100	100	10	10

Notes:

- I_{IL} is the input leakage current per I/O pin over recommended operating conditions where $-0.3 < V_{IN} < V_{IL}$.
- I_{IH} is the input leakage current per I/O pin over recommended operating conditions where $V_{IH} < V_{IN} < V_{CCI}$. Input current is larger when operating outside recommended ranges.
- Currents are measured at 85°C junction temperature.
- All LVCMOS 3.3 V software macros support LVCMOS 3.3 V Wide Range, as specified in the JEDEC JESD8-B specification.

2.5 V LVCMOS

Low-Voltage CMOS for 2.5 V is an extension of the LVCMOS standard (JESD8-5) used for general-purpose 2.5 V applications. It uses a 5 V-tolerant input buffer and push-pull output buffer.

Table 2-40 • Minimum and Maximum DC Input and Output Levels

2.5 V LVCMOS Drive Strength	V_{IL}		V_{IH}		V_{OL}	V_{OH}	I_{OL}	I_{OH}	I_{OSL}	I_{OSH}	I_{IL}^1	I_{IH}^2
	Min., V	Max., V	Min., V	Max., V	Max., V	Min., V	mA	mA	Max., mA ³	Max., mA ³	μA^4	μA^4
2 mA	-0.3	0.7	1.7	3.6	0.7	1.7	2	2	16	18	10	10
4 mA	-0.3	0.7	1.7	3.6	0.7	1.7	4	4	16	18	10	10
6 mA	-0.3	0.7	1.7	3.6	0.7	1.7	6	6	32	37	10	10
8 mA	-0.3	0.7	1.7	3.6	0.7	1.7	8	8	32	37	10	10

Notes:

1. I_{IL} is the input leakage current per I/O pin over recommended operating conditions where $-0.3 < V_{IN} < V_{IL}$.
2. I_{IH} is the input leakage current per I/O pin over recommended operating conditions where $V_{IH} < V_{IN} < V_{CCI}$. Input current is larger when operating outside recommended ranges.
3. Currents are measured at high temperature (100°C junction temperature) and maximum voltage.
4. Currents are measured at 85°C junction temperature.
5. Software default selection highlighted in gray.

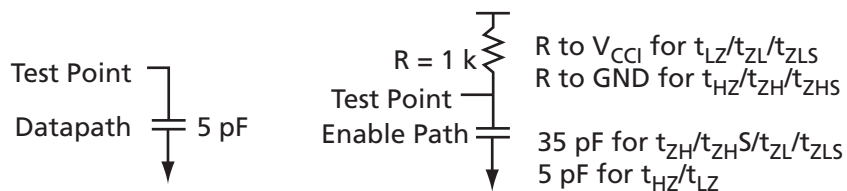

Figure 2-8 • AC Loading

Table 2-41 • 2.5 V LVCMOS AC Waveforms, Measuring Points, and Capacitive Loads

Input LOW (V)	Input HIGH (V)	Measuring Point* (V)	C_{LOAD} (pF)
0	2.5	1.2	5

* Measuring point = V_{trip} . See Table 2-22 on page 2-20 for a complete table of trip points.

Timing Characteristics

Applies to 1.5 V DC Core Voltage

Table 2-42 • 2.5 V LVC MOS Low Slew – Applies to 1.5 V DC Core Voltage
Commercial-Case Conditions: $T_J = 70^\circ\text{C}$, Worst-Case $V_{CC} = 1.425\text{ V}$, Worst-Case $V_{CCI} = 2.3\text{ V}$

Drive Strength	Speed Grade	t_{DOUT}	t_{DP}	t_{DIN}	t_{PY}	t_{PYS}	t_{EOUT}	t_{ZL}	t_{ZH}	t_{LZ}	t_{HZ}	Units
2 mA	STD	0.97	4.44	0.19	1.06	1.22	0.66	3.87	3.47	1.80	1.70	ns
4 mA	STD	0.97	4.44	0.19	1.06	1.22	0.66	3.87	3.47	1.80	1.70	ns
8 mA	STD	0.97	3.61	0.19	1.06	1.22	0.66	3.27	3.11	2.05	2.17	ns
8 mA	STD	0.97	3.61	0.19	1.06	1.22	0.66	3.27	3.11	2.05	2.17	ns

Note: For specific junction temperature and voltage supply levels, refer to [Table 2-6 on page 2-6](#) for derating values.

Table 2-43 • 2.5 V LVC MOS High Slew – Applies to 1.5 V DC Core Voltage
Commercial-Case Conditions: $T_J = 70^\circ\text{C}$, Worst-Case $V_{CC} = 1.425\text{ V}$, Worst-Case $V_{CCI} = 2.3\text{ V}$

Drive Strength	Speed Grade	t_{DOUT}	t_{DP}	t_{DIN}	t_{PY}	t_{PYS}	t_{EOUT}	t_{ZL}	t_{ZH}	t_{LZ}	t_{HZ}	Units
2 mA	STD	0.97	2.41	0.19	1.06	1.22	0.66	1.93	1.57	1.79	1.77	ns
4 mA	STD	0.97	2.41	0.19	1.06	1.22	0.66	1.93	1.57	1.79	1.77	ns
6 mA	STD	0.97	1.99	0.19	1.06	1.22	0.66	1.76	1.42	2.04	2.25	ns
8 mA	STD	0.97	1.99	0.19	1.06	1.22	0.66	1.76	1.42	2.04	2.25	ns

Notes:

1. Software default selection highlighted in gray.
2. For specific junction temperature and voltage supply levels, refer to [Table 2-6 on page 2-6](#) for derating values.

Applies to 1.2 V DC Core Voltage
Table 2-44 • 2.5 LVCMOS Low Slew – Applies to 1.2 V DC Core Voltage
 Commercial-Case Conditions: $T_J = 70^\circ\text{C}$, Worst-Case $V_{CC} = 1.14\text{ V}$, Worst-Case $V_{CCI} = 2.3\text{ V}$

Drive Strength	Speed Grade	t_{DOUT}	t_{DP}	t_{DIN}	t_{PY}	t_{PYS}	t_{EOUT}	t_{ZL}	t_{ZH}	t_{LZ}	t_{HZ}	Units
2 mA	STD	1.55	5.75	0.26	1.20	1.22	1.10	5.05	4.57	2.21	2.35	ns
4 mA	STD	1.55	5.75	0.26	1.20	1.22	1.10	5.05	4.57	2.21	2.35	ns
6 mA	STD	1.55	4.63	0.26	1.20	1.22	1.10	4.21	3.94	2.47	2.83	ns
8 mA	STD	1.55	4.63	0.26	1.20	1.22	1.10	4.21	3.94	2.47	2.83	ns

Note: For specific junction temperature and voltage supply levels, refer to [Table 2-6 on page 2-6](#) for derating values.

Table 2-45 • 2.5 V LVCMOS High Slew – Applies to 1.2 V DC Core Voltage
 Commercial-Case Conditions: $T_J = 70^\circ\text{C}$, Worst-Case $V_{CC} = 1.14\text{ V}$, Worst-Case $V_{CCI} = 2.3\text{ V}$

Drive Strength	Speed Grade	t_{DOUT}	t_{DP}	t_{DIN}	t_{PY}	t_{PYS}	t_{EOUT}	t_{ZL}	t_{ZH}	t_{LZ}	t_{HZ}	Units
2 mA	STD	1.55	3.52	0.26	1.20	1.22	1.10	2.94	2.60	2.21	2.44	ns
4 mA	STD	1.55	3.52	0.26	1.20	1.22	1.10	2.94	2.60	2.21	2.44	ns
6 mA	STD	1.55	2.82	0.26	1.20	1.22	1.10	2.53	2.15	2.46	2.93	ns
8 mA	STD	1.55	2.82	0.26	1.20	1.22	1.10	2.53	2.15	2.46	2.93	ns

Notes:

1. Software default selection highlighted in gray.
2. For specific junction temperature and voltage supply levels, refer to [Table 2-6 on page 2-6](#) for derating values.

1.8 V LVCMOS

Low-voltage CMOS for 1.8 V is an extension of the LVCMOS standard (JESD8-5) used for general-purpose 1.8 V applications. It uses a 1.8 V input buffer and a push-pull output buffer.

Table 2-46 • Minimum and Maximum DC Input and Output Levels

1.8 V LVCMOS Drive Strength	V_{IL}		V_{IH}		V_{OL}	V_{OH}	I_{OL}	I_{OH}	I_{OSL}	I_{OSH}	I_{IL}^1	I_{IH}^2
	Min., V	Max., V	Min., V	Max., V	Max., V	Min., V	mA	mA	Max., mA ³	Max., mA ³	μA^4	μA^4
2 mA	-0.3	0.35 * V_{CC1}	0.65 * V_{CC1}	3.6	0.45	$V_{CC1} - 0.45$	2	2	9	11	10	10
4 mA	-0.3	0.35 * V_{CC1}	0.65 * V_{CC1}	3.6	0.45	$V_{CC1} - 0.45$	4	4	17	22	10	10

Notes:

1. I_{IL} is the input leakage current per I/O pin over recommended operating conditions where $-0.3 < V_{IN} < V_{IL}$.
2. I_{IH} is the input leakage current per I/O pin over recommended operating conditions where $V_{IH} < V_{IN} < V_{CC1}$. Input current is larger when operating outside recommended ranges.
3. Currents are measured at high temperature (100°C junction temperature) and maximum voltage.
4. Currents are measured at 85°C junction temperature.
5. Software default selection highlighted in gray.

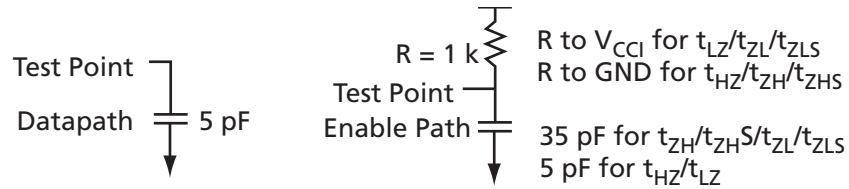

Figure 2-9 • AC Loading

Table 2-47 • 1.8 V LVCMOS AC Waveforms, Measuring Points, and Capacitive Loads

Input LOW (V)	Input HIGH (V)	Measuring Point* (V)	C_{LOAD} (pF)
0	1.8	0.9	5

* Measuring point = V_{trip} . See Table 2-22 on page 2-20 for a complete table of trip points.

Timing Characteristics

Applies to 1.5 V DC Core Voltage

Table 2-48 • 1.8 V LVCMOS Low Slew – Applies to 1.5 V DC Core Voltage
Commercial-Case Conditions: $T_J = 70^\circ\text{C}$, Worst-Case $V_{CC} = 1.425\text{ V}$, Worst-Case $V_{CCI} = 1.7\text{ V}$

Drive Strength	Speed Grade	t_{DOUT}	t_{DP}	t_{DIN}	t_{PY}	t_{PYS}	t_{EOUT}	t_{ZL}	t_{ZH}	t_{LZ}	t_{HZ}	Units
2 mA	STD	0.97	5.89	0.19	0.99	1.43	0.66	5.20	4.48	1.78	1.30	ns
4 mA	STD	0.97	4.82	0.19	0.99	1.43	0.66	4.39	4.04	2.08	2.07	ns

Note: For specific junction temperature and voltage supply levels, refer to [Table 2-6 on page 2-6](#) for derating values.

Table 2-49 • 1.8 V LVCMOS High Slew – Applies to 1.5 V DC Core Voltage
Commercial-Case Conditions: $T_J = 70^\circ\text{C}$, Worst-Case $V_{CC} = 1.425\text{ V}$, Worst-Case $V_{CCI} = 1.7\text{ V}$

Drive Strength	Speed Grade	t_{DOUT}	t_{DP}	t_{DIN}	t_{PY}	t_{PYS}	t_{EOUT}	t_{ZL}	t_{ZH}	t_{LZ}	t_{HZ}	Units
2 mA	STD	0.97	2.82	0.19	0.99	1.43	0.66	2.25	1.86	1.78	1.35	ns
4 mA	STD	0.97	2.30	0.19	0.99	1.43	0.66	2.01	1.64	2.08	2.15	ns

Notes:

1. Software default selection highlighted in gray.
2. For specific junction temperature and voltage supply levels, refer to [Table 2-6 on page 2-6](#) for derating values.

Applies to 1.2 V DC Core Voltage

Table 2-50 • 1.8 V LVCMOS Low Slew – Applies to 1.2 V DC Core Voltage
Commercial-Case Conditions: $T_J = 70^\circ\text{C}$, Worst-Case $V_{CC} = 1.14\text{ V}$, Worst-Case $V_{CCI} = 1.7\text{ V}$

Drive Strength	Speed Grade	t_{DOUT}	t_{DP}	t_{DIN}	t_{PY}	t_{PYS}	t_{EOUT}	t_{ZL}	t_{ZH}	t_{LZ}	t_{HZ}	Units
2 mA	STD	1.55	7.30	0.26	1.12	1.43	1.10	6.45	5.82	2.18	1.87	ns
4 mA	STD	1.55	5.88	0.26	1.12	1.43	1.10	5.35	4.98	2.49	2.67	ns

Note: For specific junction temperature and voltage supply levels, refer to [Table 2-6 on page 2-6](#) for derating values.

Table 2-51 • 1.8 V LVCMOS High Slew – Applies to 1.2 V DC Core Voltage
Commercial-Case Conditions: $T_J = 70^\circ\text{C}$, Worst-Case $V_{CC} = 1.14\text{ V}$, Worst-Case $V_{CCI} = 1.7\text{ V}$

Drive Strength	Speed Grade	t_{DOUT}	t_{DP}	t_{DIN}	t_{PY}	t_{PYS}	t_{EOUT}	t_{ZL}	t_{ZH}	t_{LZ}	t_{HZ}	Units
2 mA	STD	1.55	4.24	0.26	1.12	1.43	1.10	3.28	3.11	2.18	1.92	ns
4 mA	STD	1.55	3.11	0.26	1.12	1.43	1.10	2.76	2.46	2.49	2.75	ns

Notes:

1. Software default selection highlighted in gray.
2. For specific junction temperature and voltage supply levels, refer to [Table 2-6 on page 2-6](#) for derating values.

1.5 V LVCMOS (JESD8-11)

Low-Voltage CMOS for 1.5 V is an extension of the LVCMOS standard (JESD8-5) used for general-purpose 1.5 V applications. It uses a 1.5 V input buffer and a push-pull output buffer.

Table 2-52 • Minimum and Maximum DC Input and Output Levels

1.5 V LVCMOS	V_{IL}		V_{IH}		V_{OL}	V_{OH}	I_{OL}	I_{OH}	I_{OSL}	I_{OSH}	I_{IL}^1	I_{IH}^2
	Min., V	Max., V	Min., V	Max., V	Max., V	Min., V	mA	mA	Max., mA ³	Max., mA ³	μA^4	μA^4
2 mA	-0.3	0.35 * V_{CC1}	0.65 * V_{CC1}	3.6	0.25 * V_{CC1}	0.75 * V_{CC1}	2	2	13	16	10	10

Notes:

1. I_{IL} is the input leakage current per I/O pin over recommended operating conditions where $-0.3 < V_{IN} < V_{IL}$.
2. I_{IH} is the input leakage current per I/O pin over recommended operating conditions where $V_{IH} < V_{IN} < V_{CC1}$. Input current is larger when operating outside recommended ranges.
3. Currents are measured at high temperature (100°C junction temperature) and maximum voltage.
4. Currents are measured at 85°C junction temperature.
5. Software default selection highlighted in gray.

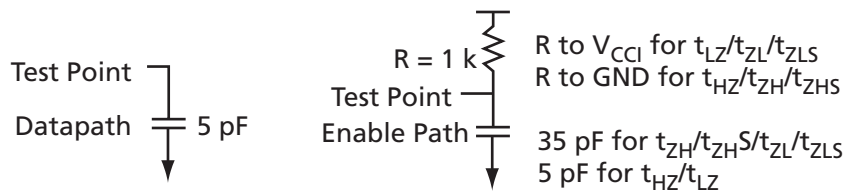

Figure 2-10 • AC Loading

Table 2-53 • 1.5 V LVCMOS AC Waveforms, Measuring Points, and Capacitive Loads

Input LOW (V)	Input HIGH (V)	Measuring Point* (V)	C_{LOAD} (pF)
0	1.5	0.75	5

* Measuring point = V_{trip} . See Table 2-22 on page 2-20 for a complete table of trip points.

Timing Characteristics

Applies to 1.5 V DC Core Voltage

Table 2-54 • 1.5 V LVCMOS Low Slew – Applies to 1.5 V DC Core Voltage
 Commercial-Case Conditions: $T_J = 70^\circ\text{C}$, Worst-Case $V_{CC} = 1.425\text{ V}$, Worst-Case $V_{CCI} = 1.4\text{ V}$

Drive Strength	Speed Grade	t_{DOUT}	t_{DP}	t_{DIN}	t_{PY}	t_{PYS}	t_{EOUT}	t_{ZL}	t_{ZH}	t_{LZ}	t_{HZ}	Units
2 mA	STD	0.97	6.07	0.19	1.15	1.62	0.66	5.57	4.89	2.13	2.02	ns

Note: For specific junction temperature and voltage supply levels, refer to [Table 2-6 on page 2-6](#) for derating values.

Table 2-55 • 1.5 V LVCMOS High Slew – Applies to 1.5 V DC Core Voltage
 Commercial-Case Conditions: $T_J = 70^\circ\text{C}$, Worst-Case $V_{CC} = 1.425\text{ V}$, Worst-Case $V_{CCI} = 1.4\text{ V}$

Drive Strength	Speed Grade	t_{DOUT}	t_{DP}	t_{DIN}	t_{PY}	t_{PYS}	t_{EOUT}	t_{ZL}	t_{ZH}	t_{LZ}	t_{HZ}	Units
2 mA	STD	0.97	2.65	0.19	1.15	1.62	0.66	2.31	1.85	2.13	2.11	ns

Notes:

1. Software default selection highlighted in gray.
2. For specific junction temperature and voltage supply levels, refer to [Table 2-6 on page 2-6](#) for derating values.

Applies to 1.2 V DC Core Voltage

Table 2-56 • 1.5 V LVCMOS Low Slew – Applies to 1.2 V DC Core Voltage
 Commercial-Case Conditions: $T_J = 70^\circ\text{C}$, Worst-Case $V_{CC} = 1.14\text{ V}$, Worst-Case $V_{CCI} = 1.4\text{ V}$

Drive Strength	Speed Grade	t_{DOUT}	t_{DP}	t_{DIN}	t_{PY}	t_{PYS}	t_{EOUT}	t_{ZL}	t_{ZH}	t_{LZ}	t_{HZ}	Units
2 mA	STD	1.55	7.23	0.26	1.26	1.62	1.10	6.61	5.94	2.53	2.58	ns

Note: For specific junction temperature and voltage supply levels, refer to [Table 2-6 on page 2-6](#) for derating values.

Table 2-57 • 1.5 V LVCMOS High Slew – Applies to 1.2 V DC Core Voltage
 Commercial-Case Conditions: $T_J = 70^\circ\text{C}$, Worst-Case $V_{CC} = 1.14\text{ V}$, Worst-Case $V_{CCI} = 1.4\text{ V}$

Drive Strength	Speed Grade	t_{DOUT}	t_{DP}	t_{DIN}	t_{PY}	t_{PYS}	t_{EOUT}	t_{ZL}	t_{ZH}	t_{LZ}	t_{HZ}	Units
2 mA	STD	1.55	3.50	0.26	1.26	1.62	1.10	3.09	2.76	2.53	2.67	ns

Notes:

1. Software default selection highlighted in gray.
2. For specific junction temperature and voltage supply levels, refer to [Table 2-6 on page 2-6](#) for derating values.

1.2 V LVCMOS (JESD8-12A)

Low-Voltage CMOS for 1.2 V complies with the LVCMOS standard JESD8-12A for general purpose 1.2 V applications. It uses a 1.2 V input buffer and a push-pull output buffer.

Table 2-58 • Minimum and Maximum DC Input and Output Levels

1.2 V LVCMOS	V_{IL}		V_{IH}		V_{OL}	V_{OH}	I_{OL}	I_{OH}	I_{OSL}	I_{OSH}	I_{IL}^1	I_{IH}^2
Drive Strength	Min., V	Max., V	Min., V	Max., V	Max., V	Min., V	mA	mA	Max., mA ³	Max., mA ³	μA^4	μA^4
1 mA	-0.3	0.35 * V_{CC1}	0.65 * V_{CC1}	3.6	0.25 * V_{CC1}	0.75 * V_{CC1}	1	1	TBD	TBD	10	10

Notes:

1. I_{IL} is the input leakage current per I/O pin over recommended operating conditions where $-0.3 < V_{IN} < V_{IL}$.
2. I_{IH} is the input leakage current per I/O pin over recommended operating conditions where $V_{IH} < V_{IN} < V_{CC1}$. Input current is larger when operating outside recommended ranges.
3. Currents are measured at high temperature (100°C junction temperature) and maximum voltage.
4. Currents are measured at 85°C junction temperature.
5. Software default selection highlighted in gray.

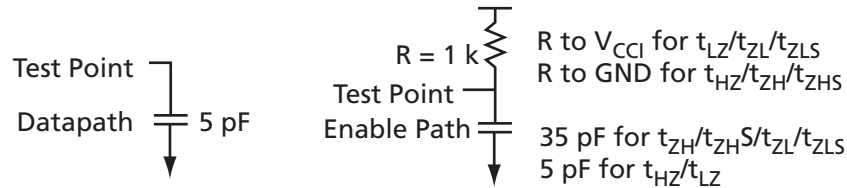

Figure 2-11 • AC Loading

Table 2-59 • 1.2 V LVCMOS AC Waveforms, Measuring Points, and Capacitive Loads

Input LOW (V)	Input HIGH (V)	Measuring Point* (V)	C_{LOAD} (pF)
0	1.2	0.6	5

* Measuring point = V_{trip} . See Table 2-22 on page 2-20 for a complete table of trip points.

Timing Characteristics

Applies to 1.2 V DC Core Voltage

Table 2-60 • 1.2 V LVCMOS Low Slew

Commercial-Case Conditions: $T_J = 70^\circ C$, Worst-Case $V_{CC} = 1.14 V$, Worst-Case $V_{CC1} = 1.14 V$

Drive Strength	Speed Grade	t_{DOUT}	t_{DP}	t_{DIN}	t_{PY}	t_{PYS}	t_{EOUT}	t_{ZL}	t_{ZH}	t_{LZ}	t_{HZ}	Units
1 mA	STD	1.55	10.33	0.26	1.56	1.66	1.10	8.52	7.30	3.00	3.12	ns

Note: For specific junction temperature and voltage supply levels, refer to Table 2-6 on page 2-6 for derating values.

Table 2-61 • 1.2 V LVCMOS High Slew

Commercial-Case Conditions: $T_J = 70^\circ C$, Worst-Case $V_{CC} = 1.14 V$, Worst-Case $V_{CC1} = 1.14 V$

Drive Strength	Speed Grade	t_{DOUT}	t_{DP}	t_{DIN}	t_{PY}	t_{PYS}	t_{EOUT}	t_{ZL}	t_{ZH}	t_{LZ}	t_{HZ}	Units
1 mA	STD	1.55	4.47	0.26	1.56	1.66	1.10	3.56	3.18	3.00	3.25	ns

Note: For specific junction temperature and voltage supply levels, refer to Table 2-6 on page 2-6 for derating values.



I/O Register Specifications

Fully Registered I/O Buffers with Asynchronous Preset

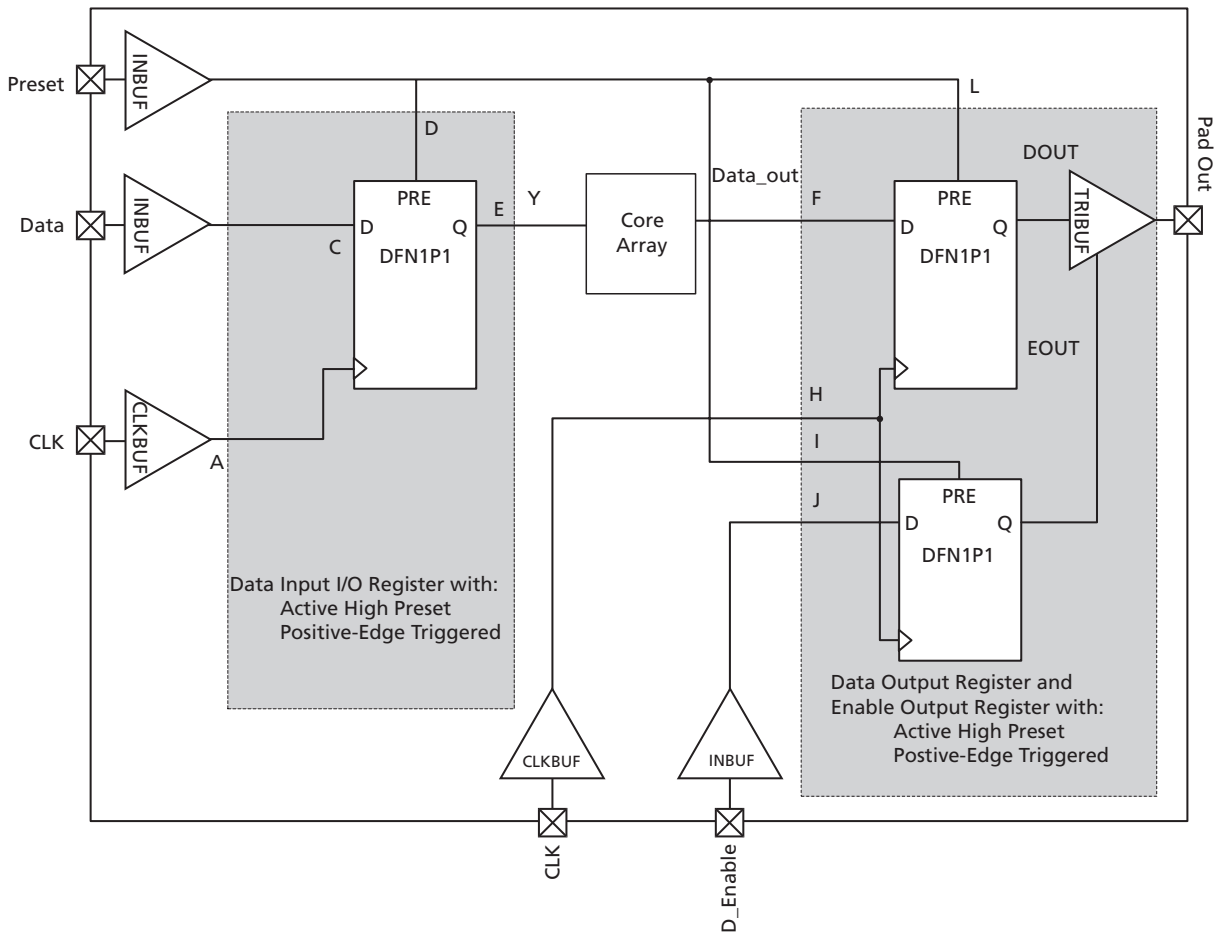

Figure 2-12 • Timing Model of Registered I/O Buffers with Asynchronous Preset

Table 2-62 • Parameter Definition and Measuring Nodes

Parameter Name	Parameter Definition	Measuring Nodes (from, to)*
t _{OCLKQ}	Clock-to-Q of the Output Data Register	H, DOUT
t _{OSUD}	Data Setup Time for the Output Data Register	F, H
t _{OHD}	Data Hold Time for the Output Data Register	F, H
t _{OPRE2Q}	Asynchronous Preset-to-Q of the Output Data Register	L, DOUT
t _{OEMPRE}	Asynchronous Preset Removal Time for the Output Data Register	L, H
t _{OECPRE}	Asynchronous Preset Recovery Time for the Output Data Register	L, H
t _{OCLKQ}	Clock-to-Q of the Output Enable Register	H, EOUT
t _{OESUD}	Data Setup Time for the Output Enable Register	J, H
t _{OEHd}	Data Hold Time for the Output Enable Register	J, H
t _{OEPRE2Q}	Asynchronous Preset-to-Q of the Output Enable Register	I, EOUT
t _{OEREMPRE}	Asynchronous Preset Removal Time for the Output Enable Register	I, H
t _{OERECPRE}	Asynchronous Preset Recovery Time for the Output Enable Register	I, H
t _{ICLKQ}	Clock-to-Q of the Input Data Register	A, E
t _{ISUD}	Data Setup Time for the Input Data Register	C, A
t _{IHD}	Data Hold Time for the Input Data Register	C, A
t _{IPRE2Q}	Asynchronous Preset-to-Q of the Input Data Register	D, E
t _{IEMPRE}	Asynchronous Preset Removal Time for the Input Data Register	D, A
t _{IECPRE}	Asynchronous Preset Recovery Time for the Input Data Register	D, A

* See Figure 2-12 on page 2-37 for more information.

Fully Registered I/O Buffers with Asynchronous Clear

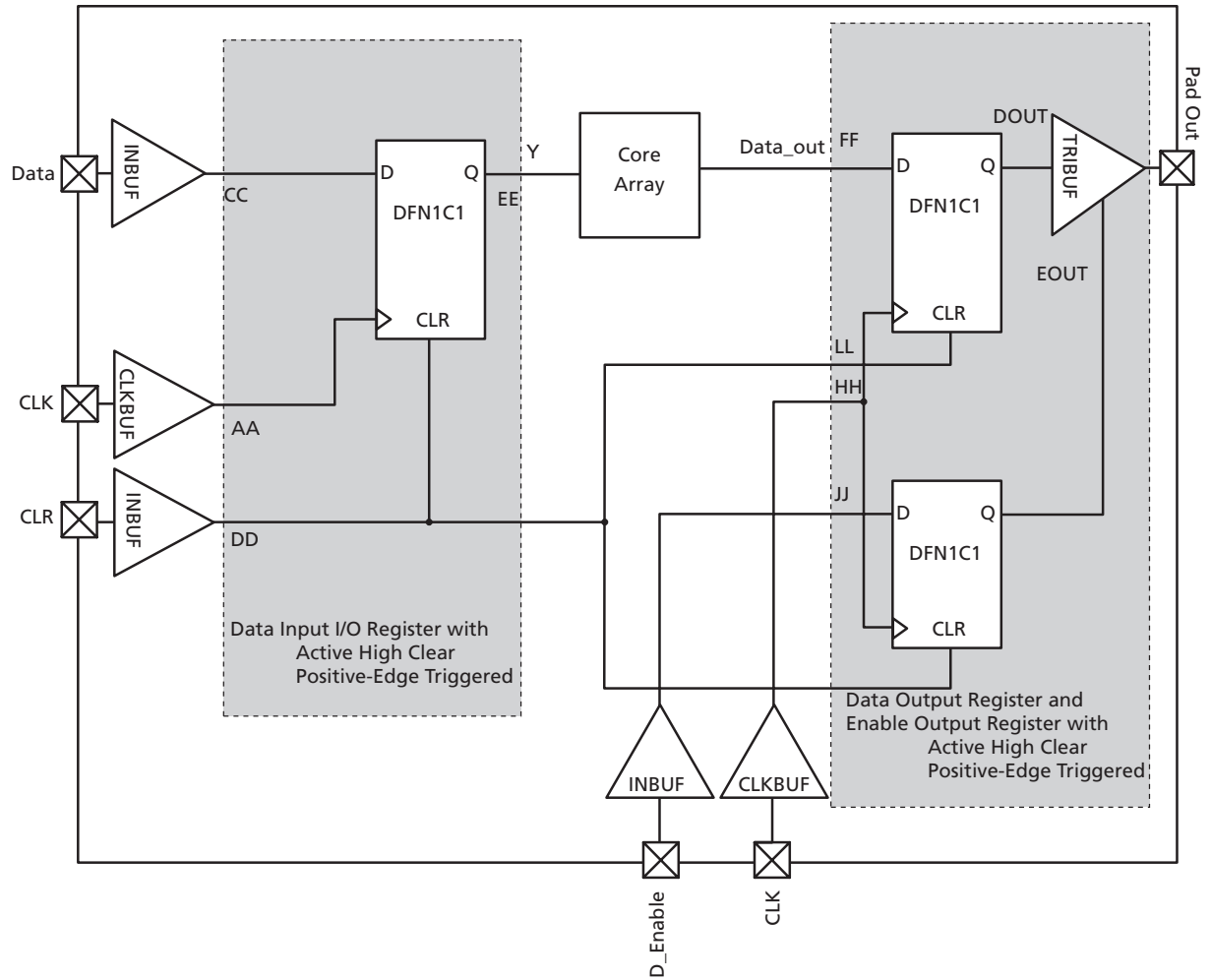

Figure 2-13 • Timing Model of the Registered I/O Buffers with Asynchronous Clear

Table 2-63 • Parameter Definition and Measuring Nodes

Parameter Name	Parameter Definition	Measuring Nodes (from, to)*
t _{OCLKQ}	Clock-to-Q of the Output Data Register	HH, DOUT
t _{OSUD}	Data Setup Time for the Output Data Register	FF, HH
t _{OHD}	Data Hold Time for the Output Data Register	FF, HH
t _{OCLR2Q}	Asynchronous Clear-to-Q of the Output Data Register	LL, DOUT
t _{OREMCLR}	Asynchronous Clear Removal Time for the Output Data Register	LL, HH
t _{ORECCLR}	Asynchronous Clear Recovery Time for the Output Data Register	LL, HH
t _{OELCKQ}	Clock-to-Q of the Output Enable Register	HH, EOUT
t _{OESUD}	Data Setup Time for the Output Enable Register	JJ, HH
t _{OEHd}	Data Hold Time for the Output Enable Register	JJ, HH
t _{OELCR2Q}	Asynchronous Clear-to-Q of the Output Enable Register	II, EOUT
t _{OEREMCLR}	Asynchronous Clear Removal Time for the Output Enable Register	II, HH
t _{OERECCLR}	Asynchronous Clear Recovery Time for the Output Enable Register	II, HH
t _{ICLKQ}	Clock-to-Q of the Input Data Register	AA, EE
t _{ISUD}	Data Setup Time for the Input Data Register	CC, AA
t _{IHD}	Data Hold Time for the Input Data Register	CC, AA
t _{ICLR2Q}	Asynchronous Clear-to-Q of the Input Data Register	DD, EE
t _{IREMCLR}	Asynchronous Clear Removal Time for the Input Data Register	DD, AA
t _{IRECCLR}	Asynchronous Clear Recovery Time for the Input Data Register	DD, AA

* See [Figure 2-13](#) on [page 2-39](#) for more information.

Input Register

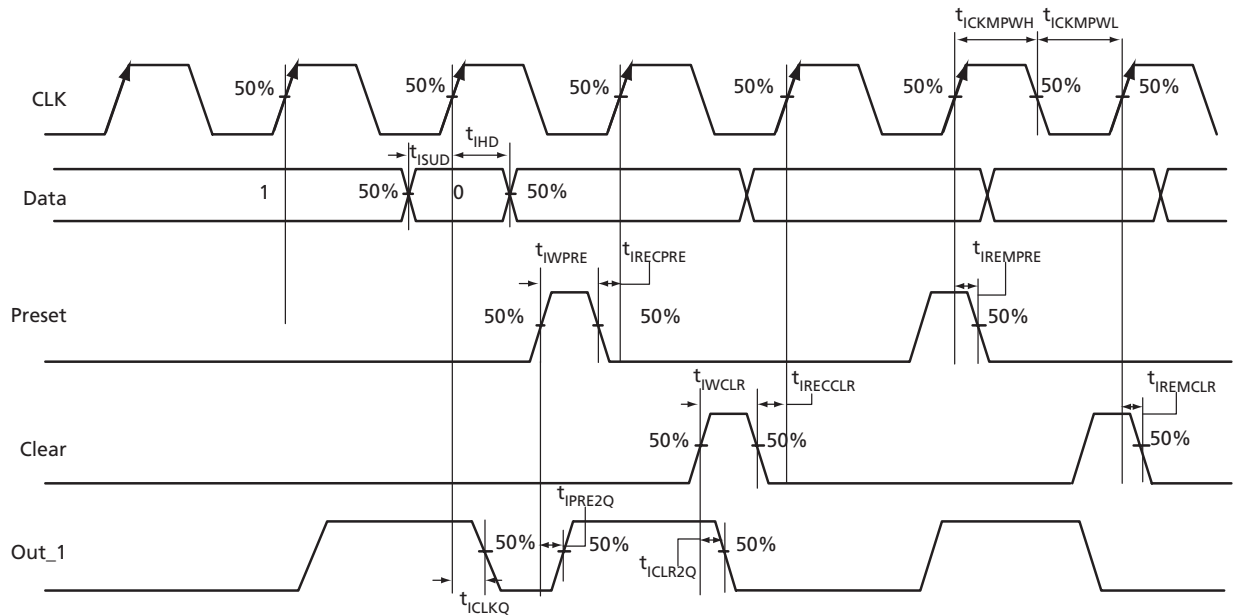

Figure 2-14 • Input Register Timing Diagram

Timing Characteristics

1.5 V DC Core Voltage

Table 2-64 • Input Data Register Propagation Delays
Commercial-Case Conditions: $T_J = 70^\circ\text{C}$, Worst-Case $V_{CC} = 1.425\text{ V}$

Parameter	Description	Std.	Units
t_{iCLKQ}	Clock-to-Q of the Input Data Register	0.42	ns
t_{iSUD}	Data Setup Time for the Input Data Register	0.47	ns
t_{iHD}	Data Hold Time for the Input Data Register	0.00	ns
t_{iCLRZQ}	Asynchronous Clear-to-Q of the Input Data Register	0.79	ns
t_{iPREZQ}	Asynchronous Preset-to-Q of the Input Data Register	0.79	ns
$t_{iREMCLR}$	Asynchronous Clear Removal Time for the Input Data Register	0.00	ns
t_{iRECLR}	Asynchronous Clear Recovery Time for the Input Data Register	0.24	ns
$t_{iREMPRE}$	Asynchronous Preset Removal Time for the Input Data Register	0.00	ns
$t_{iRECPRE}$	Asynchronous Preset Recovery Time for the Input Data Register	0.24	ns
t_{iWCLR}	Asynchronous Clear Minimum Pulse Width for the Input Data Register	0.19	ns
t_{iWPRE}	Asynchronous Preset Minimum Pulse Width for the Input Data Register	0.19	ns
$t_{iCKMPWH}$	Clock Minimum Pulse Width HIGH for the Input Data Register	0.31	ns
$t_{iCKMPWL}$	Clock Minimum Pulse Width LOW for the Input Data Register	0.28	ns

Note: For specific junction temperature and voltage supply levels, refer to Table 2-6 on page 2-6 for derating values.

1.2 V DC Core Voltage

Table 2-65 • Input Data Register Propagation Delays
 Commercial-Case Conditions: $T_J = 70^\circ\text{C}$, Worst-Case $V_{CC} = 1.14\text{ V}$

Parameter	Description	Std.	Units
t_{CLKQ}	Clock-to-Q of the Input Data Register	0.68	ns
t_{ISUD}	Data Setup Time for the Input Data Register	0.97	ns
t_{IHD}	Data Hold Time for the Input Data Register	0.00	ns
t_{CLR2Q}	Asynchronous Clear-to-Q of the Input Data Register	1.19	ns
t_{PRE2Q}	Asynchronous Preset-to-Q of the Input Data Register	1.19	ns
t_{REMCLR}	Asynchronous Clear Removal Time for the Input Data Register	0.00	ns
t_{RECCLR}	Asynchronous Clear Recovery Time for the Input Data Register	0.24	ns
t_{REMPRE}	Asynchronous Preset Removal Time for the Input Data Register	0.00	ns
t_{RECPRE}	Asynchronous Preset Recovery Time for the Input Data Register	0.24	ns
t_{IWCLR}	Asynchronous Clear Minimum Pulse Width for the Input Data Register	0.19	ns
t_{IWPRE}	Asynchronous Preset Minimum Pulse Width for the Input Data Register	0.19	ns
t_{ICKMPWH}	Clock Minimum Pulse Width HIGH for the Input Data Register	0.31	ns
t_{ICKMPWL}	Clock Minimum Pulse Width LOW for the Input Data Register	0.28	ns

Note: For specific junction temperature and voltage supply levels, refer to [Table 2-7 on page 2-7](#) for derating values.

Output Register

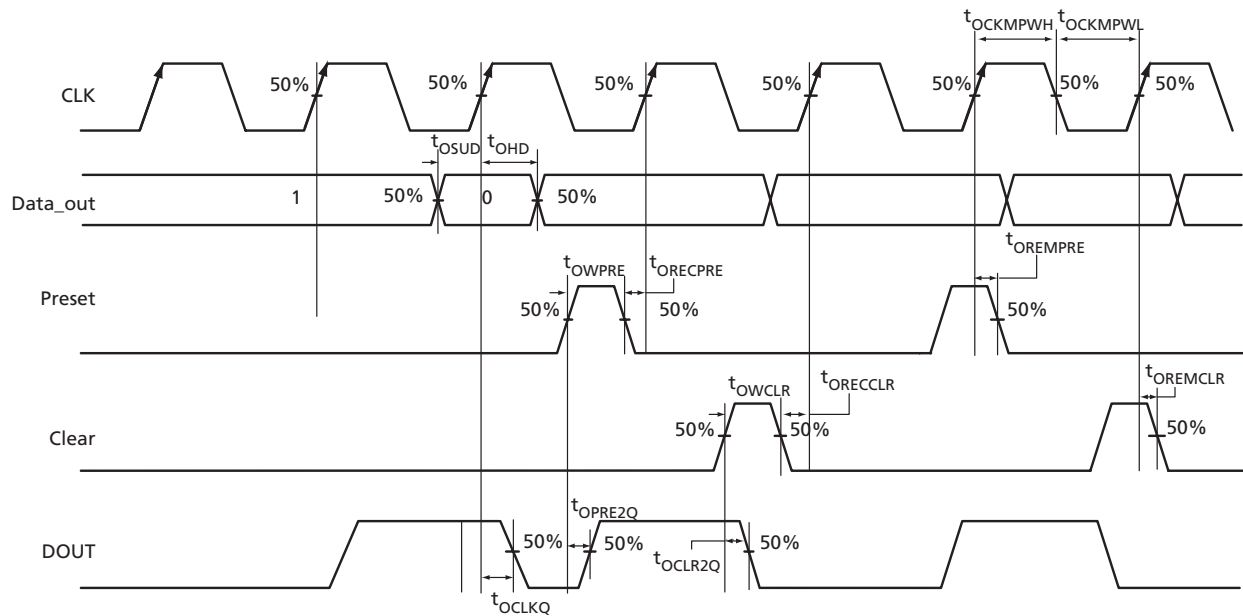

Figure 2-15 • Output Register Timing Diagram

Timing Characteristics

1.5 V DC Core Voltage

Table 2-66 • Output Data Register Propagation Delays
Commercial-Case Conditions: $T_J = 70^\circ\text{C}$, Worst-Case $V_{CC} = 1.425\text{ V}$

Parameter	Description	Std.	Units
t_{OCLKQ}	Clock-to-Q of the Output Data Register	1.00	ns
t_{OSUD}	Data Setup Time for the Output Data Register	0.51	ns
t_{OHD}	Data Hold Time for the Output Data Register	0.00	ns
t_{OCLR2Q}	Asynchronous Clear-to-Q of the Output Data Register	1.34	ns
t_{OPRE2Q}	Asynchronous Preset-to-Q of the Output Data Register	1.34	ns
t_{OEMCLR}	Asynchronous Clear Removal Time for the Output Data Register	0.00	ns
t_{OECCLR}	Asynchronous Clear Recovery Time for the Output Data Register	0.24	ns
t_{OEMPRE}	Asynchronous Preset Removal Time for the Output Data Register	0.00	ns
t_{OECPRE}	Asynchronous Preset Recovery Time for the Output Data Register	0.24	ns
t_{OWCLR}	Asynchronous Clear Minimum Pulse Width for the Output Data Register	0.19	ns
t_{OWPRE}	Asynchronous Preset Minimum Pulse Width for the Output Data Register	0.19	ns
$t_{OCKMPWH}$	Clock Minimum Pulse Width HIGH for the Output Data Register	0.31	ns
$t_{OCKMPWL}$	Clock Minimum Pulse Width LOW for the Output Data Register	0.28	ns

Note: For specific junction temperature and voltage supply levels, refer to Table 2-6 on page 2-6 for derating values.

1.2 V DC Core Voltage

Table 2-67 • Output Data Register Propagation Delays
 Commercial-Case Conditions: $T_J = 70^\circ\text{C}$, Worst-Case $V_{CC} = 1.14\text{ V}$

Parameter	Description	Std.	Units
t_{OCLKQ}	Clock-to-Q of the Output Data Register	1.52	ns
t_{OSUD}	Data Setup Time for the Output Data Register	1.15	ns
t_{OHD}	Data Hold Time for the Output Data Register	0.00	ns
t_{OCLR2Q}	Asynchronous Clear-to-Q of the Output Data Register	1.96	ns
t_{OPRE2Q}	Asynchronous Preset-to-Q of the Output Data Register	1.96	ns
$t_{OREMCLR}$	Asynchronous Clear Removal Time for the Output Data Register	0.00	ns
$t_{ORECCLR}$	Asynchronous Clear Recovery Time for the Output Data Register	0.24	ns
$t_{OREMPRE}$	Asynchronous Preset Removal Time for the Output Data Register	0.00	ns
$t_{ORECPRE}$	Asynchronous Preset Recovery Time for the Output Data Register	0.24	ns
t_{OWCLR}	Asynchronous Clear Minimum Pulse Width for the Output Data Register	0.19	ns
t_{OWPRE}	Asynchronous Preset Minimum Pulse Width for the Output Data Register	0.19	ns
$t_{OCLKMPWH}$	Clock Minimum Pulse Width HIGH for the Output Data Register	0.31	ns
$t_{OCLKMPWL}$	Clock Minimum Pulse Width LOW for the Output Data Register	0.28	ns

Note: For specific junction temperature and voltage supply levels, refer to [Table 2-7 on page 2-7](#) for derating values.

Output Enable Register

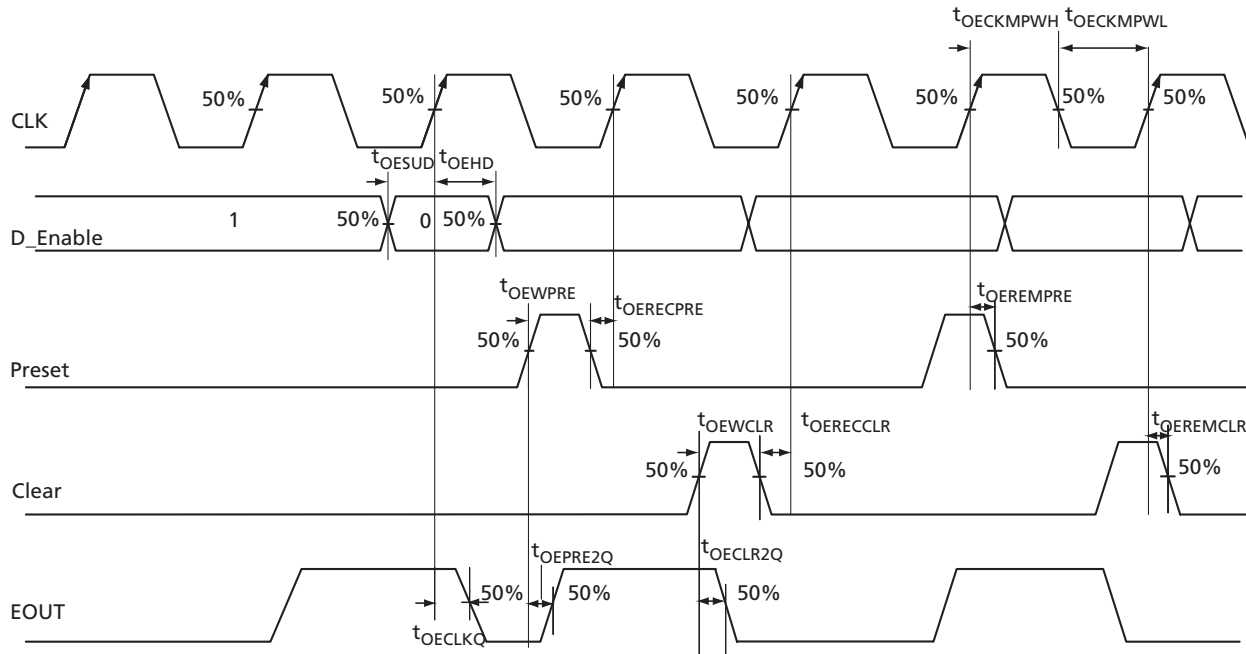

Figure 2-16 • Output Enable Register Timing Diagram

Timing Characteristics

1.5 V DC Core Voltage

Table 2-68 • Output Enable Register Propagation Delays
Commercial-Case Conditions: $T_j = 70^\circ\text{C}$, Worst-Case $V_{CC} = 1.425\text{ V}$

Parameter	Description	Std.	Units
t_{OECLKQ}	Clock-to-Q of the Output Enable Register	0.75	ns
t_{OESUD}	Data Setup Time for the Output Enable Register	0.51	ns
t_{OEHD}	Data Hold Time for the Output Enable Register	0.00	ns
$t_{OECLR2Q}$	Asynchronous Clear-to-Q of the Output Enable Register	1.13	ns
$t_{OEPRE2Q}$	Asynchronous Preset-to-Q of the Output Enable Register	1.13	ns
$t_{OEREMCLR}$	Asynchronous Clear Removal Time for the Output Enable Register	0.00	ns
$t_{OERECLR}$	Asynchronous Clear Recovery Time for the Output Enable Register	0.24	ns
$t_{OEREMPRE}$	Asynchronous Preset Removal Time for the Output Enable Register	0.00	ns
$t_{OERECPRE}$	Asynchronous Preset Recovery Time for the Output Enable Register	0.24	ns
t_{OEWCLR}	Asynchronous Clear Minimum Pulse Width for the Output Enable Register	0.19	ns
t_{OEWPRE}	Asynchronous Preset Minimum Pulse Width for the Output Enable Register	0.19	ns
$t_{OECKMPWH}$	Clock Minimum Pulse Width HIGH for the Output Enable Register	0.31	ns
$t_{OECKMPWL}$	Clock Minimum Pulse Width LOW for the Output Enable Register	0.28	ns

Note: For specific junction temperature and voltage supply levels, refer to Table 2-6 on page 2-6 for derating values.

1.2 V DC Core Voltage

Table 2-69 • Output Enable Register Propagation Delays
 Commercial-Case Conditions: $T_J = 70^\circ\text{C}$, Worst-Case $V_{CC} = 1.14\text{ V}$

Parameter	Description	Std.	Units
t_{OECLKQ}	Clock-to-Q of the Output Enable Register	1.10	ns
t_{OESUD}	Data Setup Time for the Output Enable Register	1.15	ns
t_{OEHD}	Data Hold Time for the Output Enable Register	0.00	ns
$t_{OECLR2Q}$	Asynchronous Clear-to-Q of the Output Enable Register	1.65	ns
$t_{OEPRE2Q}$	Asynchronous Preset-to-Q of the Output Enable Register	1.65	ns
$t_{OEREMCLR}$	Asynchronous Clear Removal Time for the Output Enable Register	0.00	ns
$t_{OERECCLR}$	Asynchronous Clear Recovery Time for the Output Enable Register	0.24	ns
$t_{OEREMPRE}$	Asynchronous Preset Removal Time for the Output Enable Register	0.00	ns
$t_{OERECPRE}$	Asynchronous Preset Recovery Time for the Output Enable Register	0.24	ns
$t_{OEWCCLR}$	Asynchronous Clear Minimum Pulse Width for the Output Enable Register	0.19	ns
t_{OEWPRE}	Asynchronous Preset Minimum Pulse Width for the Output Enable Register	0.19	ns
$t_{OECKMPWH}$	Clock Minimum Pulse Width HIGH for the Output Enable Register	0.31	ns
$t_{OECKMPWL}$	Clock Minimum Pulse Width LOW for the Output Enable Register	0.28	ns

Note: For specific junction temperature and voltage supply levels, refer to [Table 2-7 on page 2-7](#) for derating values.

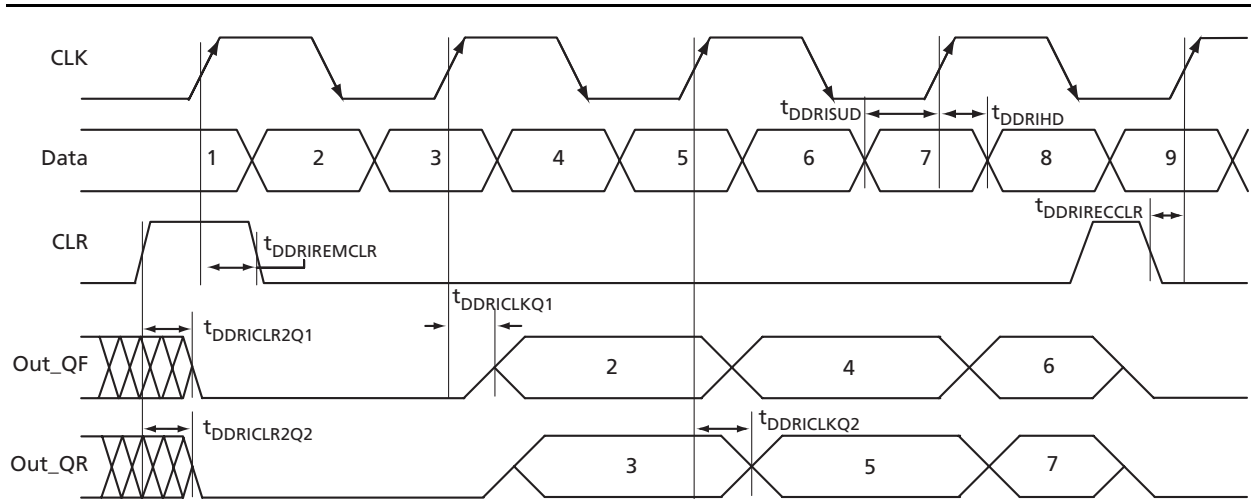

Figure 2-18 • Input DDR Timing Diagram

Timing Characteristics

1.5 V DC Core Voltage

Table 2-71 • Input DDR Propagation Delays

Commercial-Case Conditions: $T_J = 70^\circ\text{C}$, Worst-Case $V_{CC} = 1.25\text{ V}$

Parameter	Description	Std.	Units
$t_{DDRICKQ1}$	Clock-to-Out Out_QR for Input DDR	0.48	ns
$t_{DDRICKQ2}$	Clock-to-Out Out_QF for Input DDR	0.65	ns
$t_{DDRISUD1}$	Data Setup for Input DDR (negedge)	0.50	ns
$t_{DDRISUD2}$	Data Setup for Input DDR (posedge)	0.40	ns
t_{DDRHD1}	Data Hold for Input DDR (negedge)	0.00	ns
t_{DDRHD2}	Data Hold for Input DDR (posedge)	0.00	ns
$t_{DDRICLR2Q1}$	Asynchronous Clear-to-Out Out_QR for Input DDR	0.82	ns
$t_{DDRICLR2Q2}$	Asynchronous Clear-to-Out Out_QF for Input DDR	0.98	ns
$t_{DDRRECLR}$	Asynchronous Clear Recovery Time for Input DDR	0.23	ns
$t_{DDRIMWCLR}$	Asynchronous Clear Minimum Pulse Width for Input DDR	0.19	ns
$t_{DDRICKMPWH}$	Clock Minimum Pulse Width HIGH for Input DDR	0.31	ns
$t_{DDRICKMPWL}$	Clock Minimum Pulse Width LOW for Input DDR	0.28	ns
$F_{DDRIMAX}$	Maximum Frequency for Input DDR	TBD	MHz

Note: For specific junction temperature and voltage supply levels, refer to Table 2-7 on page 2-7 for derating values.



1.2 V DC Core Voltage

Table 2-72 • Input DDR Propagation Delays
 Commercial-Case Conditions: $T_J = 70^\circ\text{C}$, Worst-Case $V_{CC} = 1.14\text{ V}$

Parameter	Description	Std.	Units
t_{DDRICKQ1}	Clock-to-Out Out_QR for Input DDR	0.76	ns
t_{DDRICKQ2}	Clock-to-Out Out_QF for Input DDR	0.94	ns
t_{DDRISUD1}	Data Setup for Input DDR (negedge)	0.93	ns
t_{DDRISUD2}	Data Setup for Input DDR (posedge)	0.84	ns
t_{DDRIHD1}	Data Hold for Input DDR (negedge)	0.00	ns
t_{DDRIHD2}	Data Hold for Input DDR (posedge)	0.00	ns
$t_{\text{DDRICLR2Q1}}$	Asynchronous Clear-to-Out Out_QR for Input DDR	1.23	ns
$t_{\text{DDRICLR2Q2}}$	Asynchronous Clear-to-Out Out_QF for Input DDR	1.42	ns
$t_{\text{DDRIRECLR}}$	Asynchronous Clear Removal Time for Input DDR	0.00	ns
$t_{\text{DDRIRECLR}}$	Asynchronous Clear Recovery Time for Input DDR	0.24	ns
$t_{\text{DDR IWCLR}}$	Asynchronous Clear Minimum Pulse Width for Input DDR	0.19	ns
$t_{\text{DDRICKMPWH}}$	Clock Minimum Pulse Width HIGH for Input DDR	0.31	ns
$t_{\text{DDRICKMPWL}}$	Clock Minimum Pulse Width LOW for Input DDR	0.28	ns
F_{DDRIMAX}	Maximum Frequency for Input DDR	TBD	MHz

Note: For specific junction temperature and voltage supply levels, refer to [Table 2-7 on page 2-7](#) for derating values.

Output DDR Module

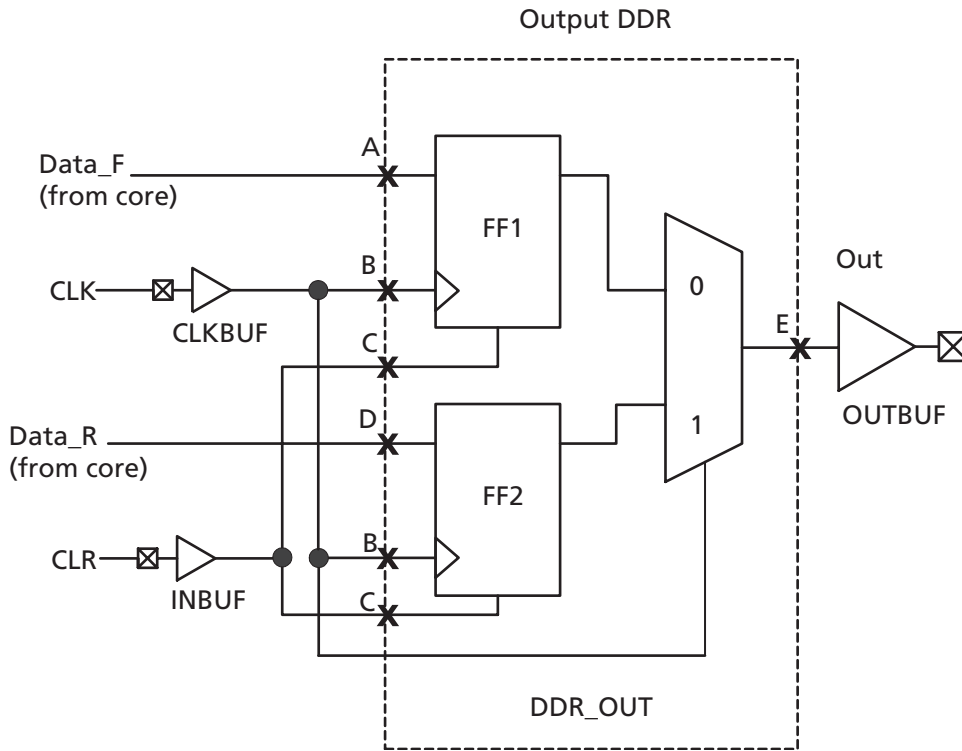
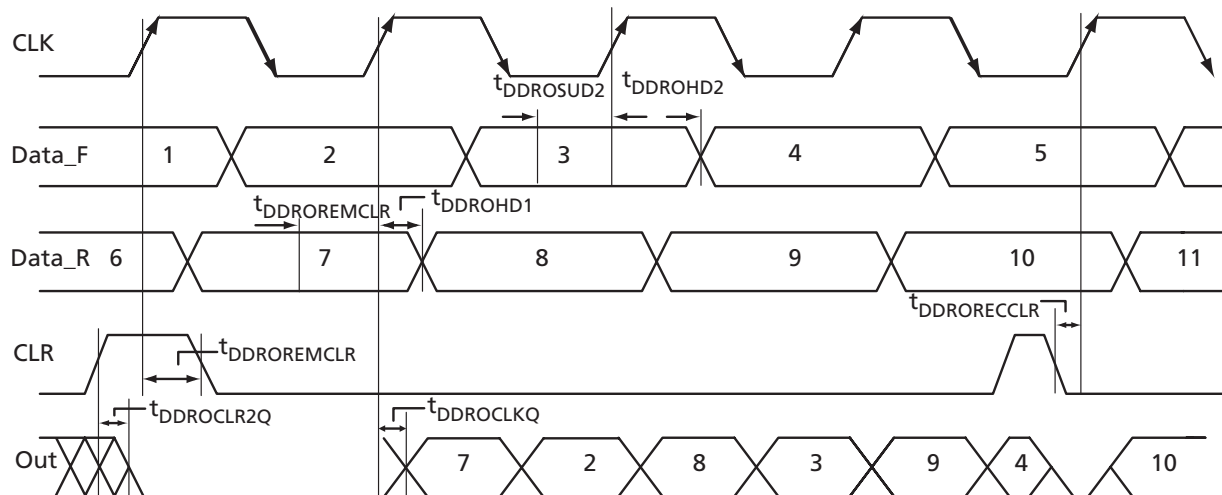

Figure 2-19 • Output DDR Timing Model

Table 2-73 • Parameter Definitions

Parameter Name	Parameter Definition	Measuring Nodes (from, to)
$t_{DDROCLKQ}$	Clock-to-Out	B, E
$t_{DDROCLR2Q}$	Asynchronous Clear-to-Out	C, E
$t_{DDROREMCLR}$	Clear Removal	C, B
$t_{DDRORECCLR}$	Clear Recovery	C, B
$t_{DDROSUD1}$	Data Setup Data_F	A, B
$t_{DDROSUD2}$	Data Setup Data_R	D, B
$t_{DDROHD1}$	Data Hold Data_F	A, B
$t_{DDROHD2}$	Data Hold Data_R	D, B

Figure 2-20 • Output DDR Timing Diagram

Timing Characteristics

1.5 V DC Core Voltage

Table 2-74 • Output DDR Propagation Delays

Commercial-Case Conditions: $T_J = 70^\circ\text{C}$, Worst-Case $V_{CC} = 1.425\text{ V}$

Parameter	Description	Std.	Units
$t_{DDROCLKQ}$	Clock-to-Out of DDR for Output DDR	1.07	ns
$t_{DDROSUD1}$	Data_F Data Setup for Output DDR	0.67	ns
$t_{DDROSUD2}$	Data_R Data Setup for Output DDR	0.67	ns
$t_{DDROHD1}$	Data_F Data Hold for Output DDR	0.00	ns
$t_{DDROHD2}$	Data_R Data Hold for Output DDR	0.00	ns
$t_{DDROCLR2Q}$	Asynchronous Clear-to-Out for Output DDR	1.38	ns
$t_{DDROEMCLR}$	Asynchronous Clear Removal Time for Output DDR	0.00	ns
$t_{DDRORECLL}$	Asynchronous Clear Recovery Time for Output DDR	0.23	ns
$t_{DDROWCLR1}$	Asynchronous Clear Minimum Pulse Width for Output DDR	0.19	ns
$t_{DDROCKMPWH}$	Clock Minimum Pulse Width HIGH for the Output DDR	0.31	ns
$t_{DDROCKMPWL}$	Clock Minimum Pulse Width LOW for the Output DDR	0.28	ns
F_{DDOMAX}	Maximum Frequency for the Output DDR	TBD	MHz

Note: For specific junction temperature and voltage supply levels, refer to Table 2-6 on page 2-6 for derating values.

1.2 V DC Core Voltage

Table 2-75 • Output DDR Propagation Delays
 Commercial-Case Conditions: $T_J = 70^\circ\text{C}$, Worst-Case $V_{CC} = 1.14\text{ V}$

Parameter	Description	Std.	Units
t_{DDROCLKQ}	Clock-to-Out of DDR for Output DDR	1.60	ns
t_{DDROSUD1}	Data_F Data Setup for Output DDR	1.09	ns
t_{DDROSUD2}	Data_R Data Setup for Output DDR	1.16	ns
t_{DDROHD1}	Data_F Data Hold for Output DDR	0.00	ns
t_{DDROHD2}	Data_R Data Hold for Output DDR	0.00	ns
$t_{\text{DDROCLR2Q}}$	Asynchronous Clear-to-Out for Output DDR	1.99	ns
$t_{\text{DDROREMCLR}}$	Asynchronous Clear Removal Time for Output DDR	0.00	ns
$t_{\text{DDRORECLR}}$	Asynchronous Clear Recovery Time for Output DDR	0.24	ns
$t_{\text{DDROWCLR1}}$	Asynchronous Clear Minimum Pulse Width for Output DDR	0.19	ns
$t_{\text{DDROCKMPWH}}$	Clock Minimum Pulse Width HIGH for the Output DDR	0.31	ns
$t_{\text{DDROCKMPWL}}$	Clock Minimum Pulse Width LOW for the Output DDR	0.28	ns
F_{DDOMAX}	Maximum Frequency for the Output DDR	TBD	MHz

Note: For specific junction temperature and voltage supply levels, refer to [Table 2-7 on page 2-7](#) for derating values.

VersaTile Characteristics

VersaTile Specifications as a Combinatorial Module

The IGLOO nano library offers all combinations of LUT-3 combinatorial functions. In this section, timing characteristics are presented for a sample of the library. For more details, refer to the *Fusion, IGLOOle, and ProASIC3/ E Macro Library Guide*.

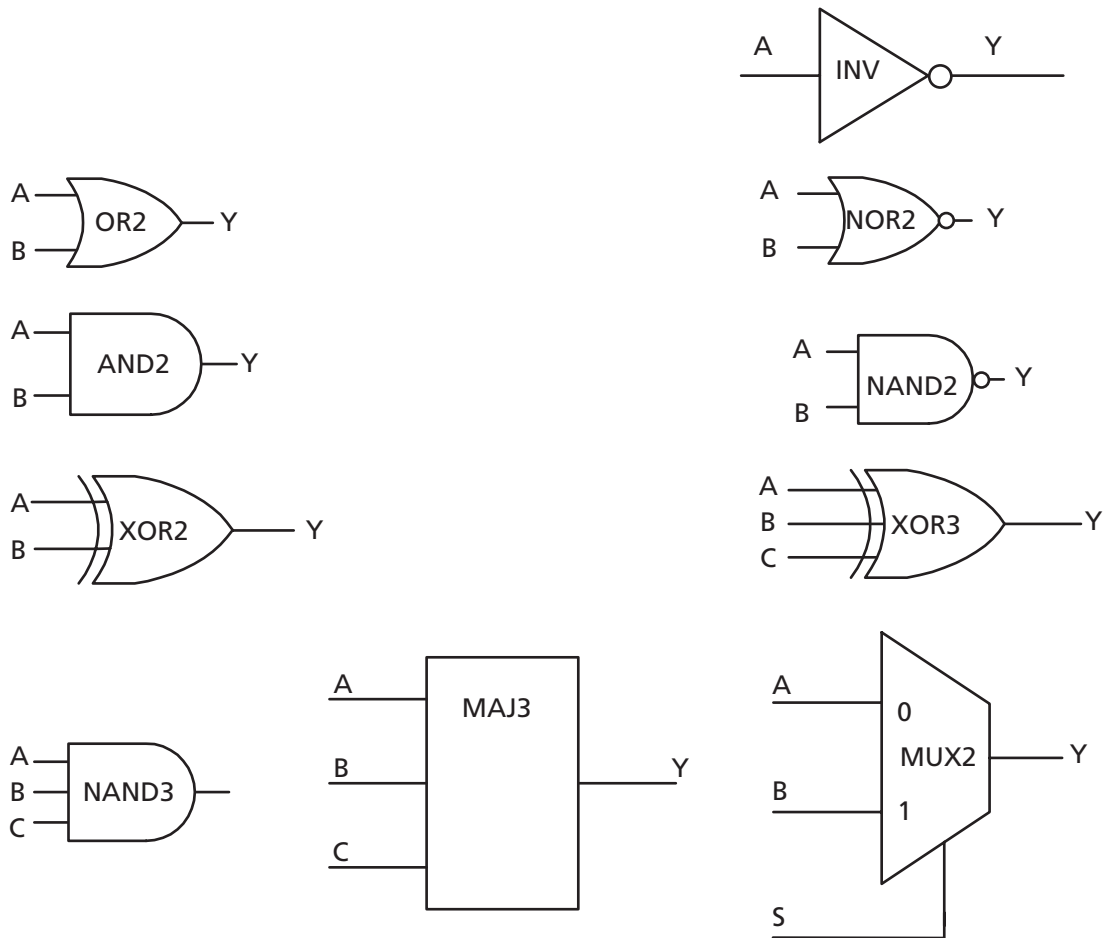

Figure 2-21 • Sample of Combinatorial Cells

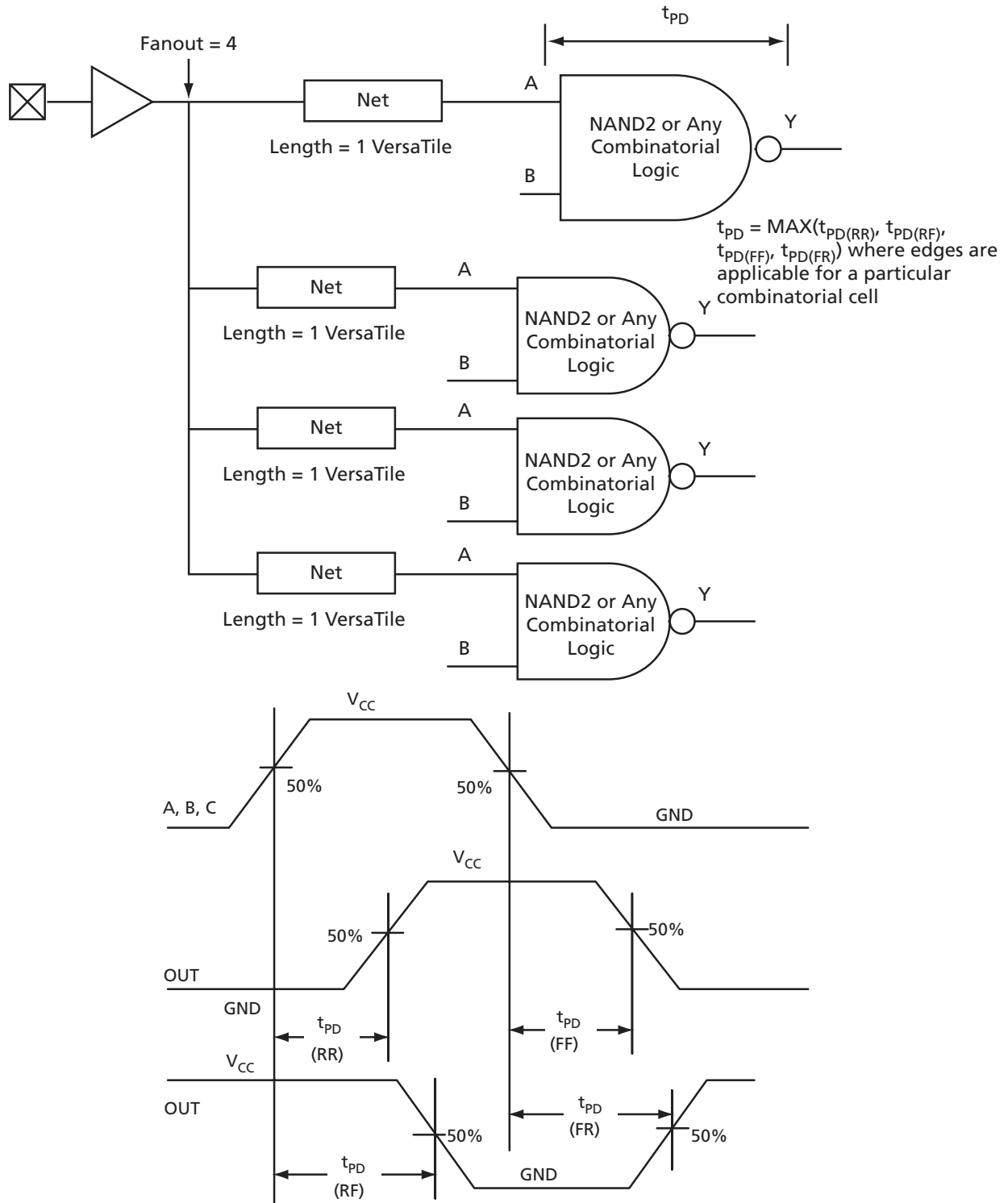

Figure 2-22 • Timing Model and Waveforms



Timing Characteristics

1.5 V DC Core Voltage

Table 2-76 • Combinatorial Cell Propagation Delays
Commercial-Case Conditions: $T_J = 70^\circ\text{C}$, Worst-Case $V_{CC} = 1.425\text{ V}$

Combinatorial Cell	Equation	Parameter	Std.	Units
INV	$Y = !A$	t_{PD}	0.76	ns
AND2	$Y = A \cdot B$	t_{PD}	0.87	ns
NAND2	$Y = !(A \cdot B)$	t_{PD}	0.91	ns
OR2	$Y = A + B$	t_{PD}	0.90	ns
NOR2	$Y = !(A + B)$	t_{PD}	0.94	ns
XOR2	$Y = A \oplus B$	t_{PD}	1.39	ns
MAJ3	$Y = \text{MAJ}(A, B, C)$	t_{PD}	1.44	ns
XOR3	$Y = A \oplus B \oplus C$	t_{PD}	1.60	ns
MUX2	$Y = A \text{ IS } + B \text{ S}$	t_{PD}	1.17	ns
AND3	$Y = A \cdot B \cdot C$	t_{PD}	1.18	ns

Note: For specific junction temperature and voltage supply levels, refer to [Table 2-6 on page 2-6](#) for derating values.

1.2 V DC Core Voltage

Table 2-77 • Combinatorial Cell Propagation Delays
Commercial-Case Conditions: $T_J = 70^\circ\text{C}$, Worst-Case $V_{CC} = 1.14\text{ V}$

Combinatorial Cell	Equation	Parameter	Std.	Units
INV	$Y = !A$	t_{PD}	1.33	ns
AND2	$Y = A \cdot B$	t_{PD}	1.48	ns
NAND2	$Y = !(A \cdot B)$	t_{PD}	1.58	ns
OR2	$Y = A + B$	t_{PD}	1.53	ns
NOR2	$Y = !(A + B)$	t_{PD}	1.63	ns
XOR2	$Y = A \oplus B$	t_{PD}	2.34	ns
MAJ3	$Y = \text{MAJ}(A, B, C)$	t_{PD}	2.59	ns
XOR3	$Y = A \oplus B \oplus C$	t_{PD}	2.74	ns
MUX2	$Y = A \text{ IS } + B \text{ S}$	t_{PD}	2.03	ns
AND3	$Y = A \cdot B \cdot C$	t_{PD}	2.11	ns

Note: For specific junction temperature and voltage supply levels, refer to [Table 2-7 on page 2-7](#) for derating values.

VersaTile Specifications as a Sequential Module

The IGLOO nano library offers a wide variety of sequential cells, including flip-flops and latches. Each has a data input and optional enable, clear, or preset. In this section, timing characteristics are presented for a representative sample from the library. For more details, refer to the *Fusion, IGLOOe, and ProASIC3/E Macro Library Guide*.

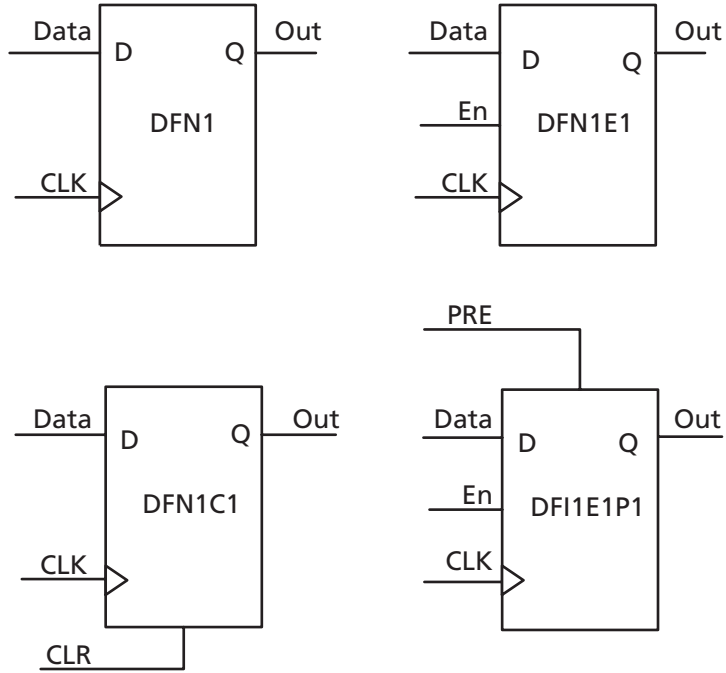
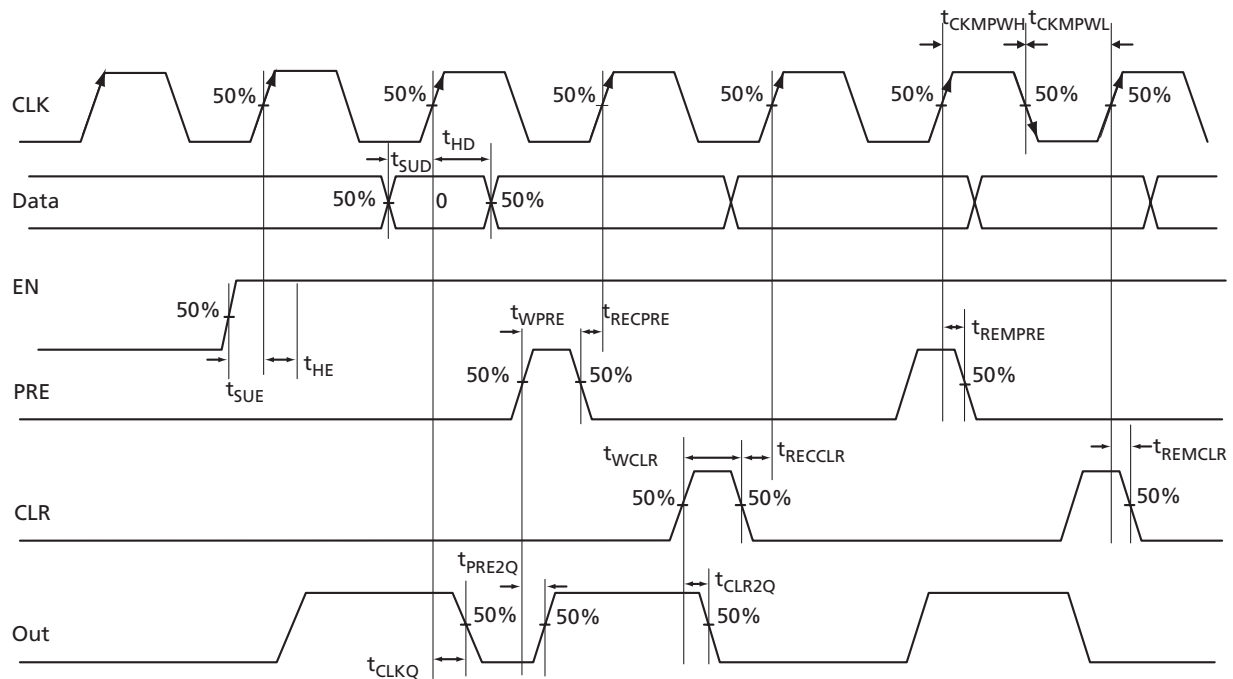

Figure 2-23 • Sample of Sequential Cells

Figure 2-24 • Timing Model and Waveforms

Timing Characteristics

1.5 V DC Core Voltage

Table 2-78 • Register Delays

Commercial-Case Conditions: $T_J = 70^\circ\text{C}$, Worst-Case $V_{CC} = 1.425\text{ V}$

Parameter	Description	Std.	Units
t_{CLKQ}	Clock-to-Q of the Core Register	0.89	ns
t_{SUD}	Data Setup Time for the Core Register	0.81	ns
t_{HD}	Data Hold Time for the Core Register	0.00	ns
t_{SUE}	Enable Setup Time for the Core Register	0.73	ns
t_{HE}	Enable Hold Time for the Core Register	0.00	ns
t_{CLR2Q}	Asynchronous Clear-to-Q of the Core Register	0.60	ns
t_{PRE2Q}	Asynchronous Preset-to-Q of the Core Register	0.62	ns
t_{REMCLR}	Asynchronous Clear Removal Time for the Core Register	0.00	ns
t_{RECCLR}	Asynchronous Clear Recovery Time for the Core Register	0.24	ns
t_{REMPRE}	Asynchronous Preset Removal Time for the Core Register	0.00	ns
t_{RECPRE}	Asynchronous Preset Recovery Time for the Core Register	0.23	ns
t_{WCLR}	Asynchronous Clear Minimum Pulse Width for the Core Register	0.30	ns
t_{WPRE}	Asynchronous Preset Minimum Pulse Width for the Core Register	0.30	ns
t_{CKMPWH}	Clock Minimum Pulse Width HIGH for the Core Register	0.56	ns
t_{CKMPWL}	Clock Minimum Pulse Width LOW for the Core Register	0.56	ns

Note: For specific junction temperature and voltage supply levels, refer to [Table 2-6 on page 2-6](#) for derating values.

1.2 V DC Core Voltage

Table 2-79 • Register Delays
 Commercial-Case Conditions: $T_J = 70^\circ\text{C}$, Worst-Case $V_{CC} = 1.14\text{ V}$

Parameter	Description	Std.	Units
t_{CLKQ}	Clock-to-Q of the Core Register	1.61	ns
t_{SUD}	Data Setup Time for the Core Register	1.17	ns
t_{HD}	Data Hold Time for the Core Register	0.00	ns
t_{SUE}	Enable Setup Time for the Core Register	1.29	ns
t_{HE}	Enable Hold Time for the Core Register	0.00	ns
t_{CLR2Q}	Asynchronous Clear-to-Q of the Core Register	0.87	ns
t_{PRE2Q}	Asynchronous Preset-to-Q of the Core Register	0.89	ns
t_{REMCLR}	Asynchronous Clear Removal Time for the Core Register	0.00	ns
t_{RECCLR}	Asynchronous Clear Recovery Time for the Core Register	0.24	ns
t_{REMPRE}	Asynchronous Preset Removal Time for the Core Register	0.00	ns
t_{RECPRE}	Asynchronous Preset Recovery Time for the Core Register	0.24	ns
t_{WCLR}	Asynchronous Clear Minimum Pulse Width for the Core Register	0.46	ns
t_{WPRE}	Asynchronous Preset Minimum Pulse Width for the Core Register	0.46	ns
t_{CKMPWH}	Clock Minimum Pulse Width HIGH for the Core Register	0.95	ns
t_{CKMPWL}	Clock Minimum Pulse Width LOW for the Core Register	0.95	ns

Note: For specific junction temperature and voltage supply levels, refer to [Table 2-7 on page 2-7](#) for derating values.

Global Resource Characteristics

AGLN125 Clock Tree Topology

Clock delays are device-specific. Figure 2-25 is an example of a global tree used for clock routing. The global tree presented in Figure 2-25 is driven by a CCC located on the west side of the AGLN125 device. It is used to drive all D-flip-flops in the device.

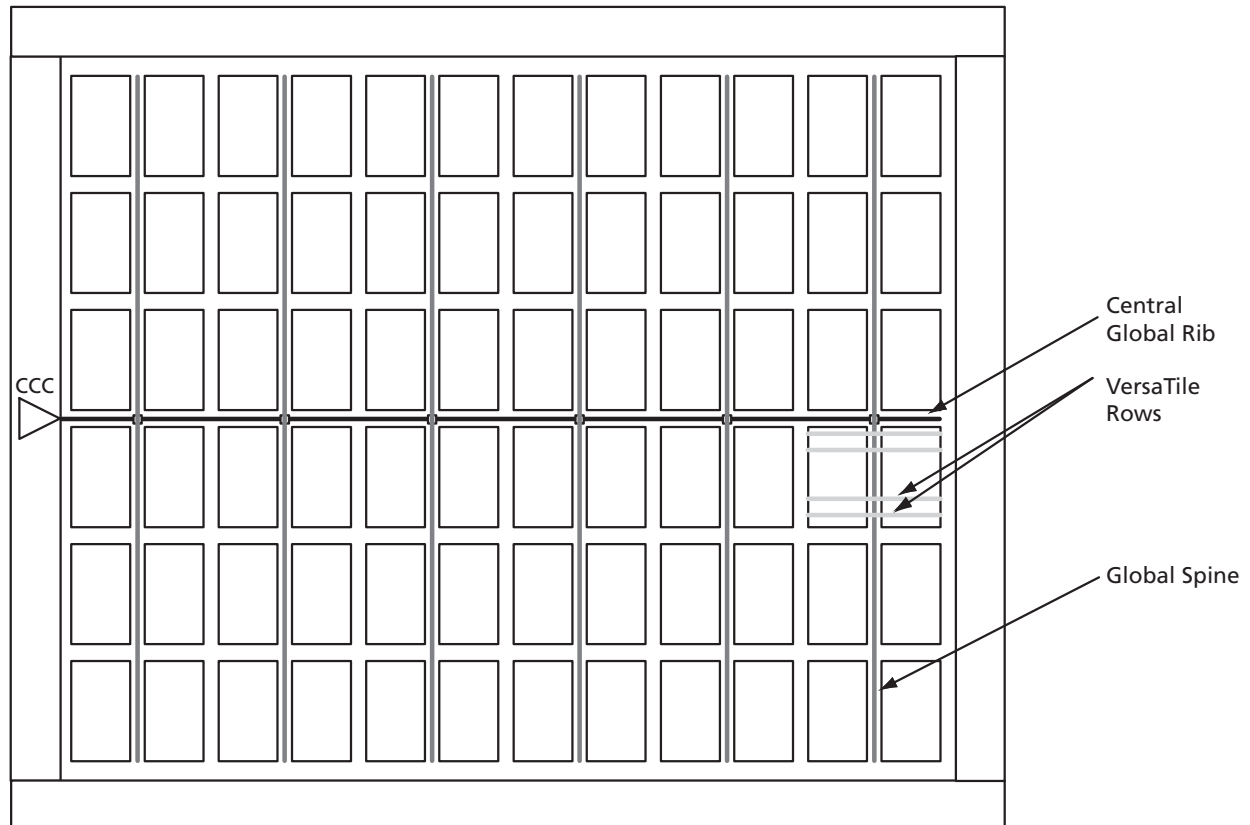

Figure 2-25 • Example of Global Tree Use in an AGLN125 Device for Clock Routing

Global Tree Timing Characteristics

Global clock delays include the central rib delay, the spine delay, and the row delay. Delays do not include I/O input buffer clock delays, as these are I/O standard-dependent, and the clock may be driven and conditioned internally by the CCC module. For more details on clock conditioning capabilities, refer to the "Clock Conditioning Circuits" section on page 2-66. Table 2-80 to Table 2-88 on page 2-64 present minimum and maximum global clock delays within each device. Minimum and maximum delays are measured with minimum and maximum loading.

Timing Characteristics

1.5 V DC Core Voltage

Table 2-80 • AGLN010 Global Resource
Commercial-Case Conditions: $T_J = 70^\circ\text{C}$, $V_{CC} = 1.425\text{ V}$

Parameter	Description	Std.		Units
		Min. ¹	Max. ²	
t_{RCKL}	Input LOW Delay for Global Clock	1.08	1.36	ns
t_{RCKH}	Input HIGH Delay for Global Clock	1.09	1.44	ns
$t_{RCKMPWH}$	Minimum Pulse Width HIGH for Global Clock			ns
$t_{RCKMPWL}$	Minimum Pulse Width LOW for Global Clock			ns
t_{RCKSW}	Maximum Skew for Global Clock		0.35	ns
F_{RMAX}	Maximum Frequency for Global Clock			MHz

Notes:

1. Value reflects minimum load. The delay is measured from the CCC output to the clock pin of a sequential element, located in a lightly loaded row (single element is connected to the global net).
2. Value reflects maximum load. The delay is measured on the clock pin of the farthest sequential element, located in a fully loaded row (all available flip-flops are connected to the global net in the row).
3. For specific junction temperature and voltage supply levels, refer to Table 2-6 on page 2-6 for derating values.

Table 2-81 • AGLN015 Global Resource
Commercial-Case Conditions: $T_J = 70^\circ\text{C}$, $V_{CC} = 1.425\text{ V}$

Parameter	Description	Std.		Units
		Min. ¹	Max. ²	
t_{RCKL}	Input LOW Delay for Global Clock	1.15	1.49	ns
t_{RCKH}	Input HIGH Delay for Global Clock	1.16	1.59	ns
$t_{RCKMPWH}$	Minimum Pulse Width HIGH for Global Clock			ns
$t_{RCKMPWL}$	Minimum Pulse Width LOW for Global Clock			ns
t_{RCKSW}	Maximum Skew for Global Clock		0.42	ns
F_{RMAX}	Maximum Frequency for Global Clock			MHz

Notes:

1. Value reflects minimum load. The delay is measured from the CCC output to the clock pin of a sequential element, located in a lightly loaded row (single element is connected to the global net).
2. Value reflects maximum load. The delay is measured on the clock pin of the farthest sequential element, located in a fully loaded row (all available flip-flops are connected to the global net in the row).
3. For specific junction temperature and voltage supply levels, refer to Table 2-6 on page 2-6 for derating values.

Table 2-82 • AGLN020 Global Resource
Commercial-Case Conditions: $T_J = 70^\circ\text{C}$, $V_{CC} = 1.425\text{ V}$

Parameter	Description	Std.		Units
		Min. ¹	Max. ²	
t_{RCKL}	Input LOW Delay for Global Clock	1.15	1.49	ns
t_{RCKH}	Input HIGH Delay for Global Clock	1.16	1.59	ns
$t_{RCKMPWH}$	Minimum Pulse Width HIGH for Global Clock			ns
$t_{RCKMPWL}$	Minimum Pulse Width LOW for Global Clock			ns
t_{RCKSW}	Maximum Skew for Global Clock		0.42	ns
F_{RMAX}	Maximum Frequency for Global Clock			MHz

Notes:

1. Value reflects minimum load. The delay is measured from the CCC output to the clock pin of a sequential element, located in a lightly loaded row (single element is connected to the global net).
2. Value reflects maximum load. The delay is measured on the clock pin of the farthest sequential element, located in a fully loaded row (all available flip-flops are connected to the global net in the row).
3. For specific junction temperature and voltage supply levels, refer to [Table 2-6 on page 2-6](#) for derating values.

Table 2-83 • AGLN060 Global Resource
Commercial-Case Conditions: $T_J = 70^\circ\text{C}$, $V_{CC} = 1.425\text{ V}$

Parameter	Description	Std.		Units
		Min. ¹	Max. ²	
t_{RCKL}	Input LOW Delay for Global Clock	1.32	1.67	ns
t_{RCKH}	Input HIGH Delay for Global Clock	1.34	1.76	ns
$t_{RCKMPWH}$	Minimum Pulse Width HIGH for Global Clock			ns
$t_{RCKMPWL}$	Minimum Pulse Width LOW for Global Clock			ns
t_{RCKSW}	Maximum Skew for Global Clock		0.42	ns
F_{RMAX}	Maximum Frequency for Global Clock			MHz

Notes:

1. Value reflects minimum load. The delay is measured from the CCC output to the clock pin of a sequential element, located in a lightly loaded row (single element is connected to the global net).
2. Value reflects maximum load. The delay is measured on the clock pin of the farthest sequential element, located in a fully loaded row (all available flip-flops are connected to the global net in the row).
3. For specific junction temperature and voltage supply levels, refer to [Table 2-6 on page 2-6](#) for derating values.

Table 2-84 • AGLN125 Global Resource
 Commercial-Case Conditions: $T_J = 70^\circ\text{C}$, $V_{CC} = 1.425\text{ V}$

Parameter	Description	Std.		Units
		Min. ¹	Max. ²	
t_{RCKL}	Input LOW Delay for Global Clock	1.36	1.71	ns
t_{RCKH}	Input HIGH Delay for Global Clock	1.39	1.82	ns
$t_{RCKMPWH}$	Minimum Pulse Width HIGH for Global Clock			ns
$t_{RCKMPWL}$	Minimum Pulse Width LOW for Global Clock			ns
t_{RCKSW}	Maximum Skew for Global Clock		0.43	ns
F_{RMAX}	Maximum Frequency for Global Clock			MHz

Notes:

1. Value reflects minimum load. The delay is measured from the CCC output to the clock pin of a sequential element, located in a lightly loaded row (single element is connected to the global net).
2. Value reflects maximum load. The delay is measured on the clock pin of the farthest sequential element, located in a fully loaded row (all available flip-flops are connected to the global net in the row).
3. For specific junction temperature and voltage supply levels, refer to [Table 2-6 on page 2-6](#) for derating values.

Table 2-85 • AGLN250 Global Resource
 Commercial-Case Conditions: $T_J = 70^\circ\text{C}$, $V_{CC} = 1.425\text{ V}$

Parameter	Description	Std.		Units
		Min. ¹	Max. ²	
t_{RCKL}	Input LOW Delay for Global Clock	1.39	1.73	ns
t_{RCKH}	Input HIGH Delay for Global Clock	1.41	1.84	ns
$t_{RCKMPWH}$	Minimum Pulse Width HIGH for Global Clock			ns
$t_{RCKMPWL}$	Minimum Pulse Width LOW for Global Clock			ns
t_{RCKSW}	Maximum Skew for Global Clock		0.43	ns
F_{RMAX}	Maximum Frequency for Global Clock			MHz

Notes:

1. Value reflects minimum load. The delay is measured from the CCC output to the clock pin of a sequential element, located in a lightly loaded row (single element is connected to the global net).
2. Value reflects maximum load. The delay is measured on the clock pin of the farthest sequential element, located in a fully loaded row (all available flip-flops are connected to the global net in the row).
3. For specific junction temperature and voltage supply levels, refer to [Table 2-6 on page 2-6](#) for derating values.

1.2 V DC Core Voltage

Table 2-86 • AGLN010 Global Resource
Commercial-Case Conditions: $T_J = 70^\circ\text{C}$, $V_{CC} = 1.14\text{ V}$

Parameter	Description	Std.		Units
		Min. ¹	Max. ²	
t_{RCKL}	Input LOW Delay for Global Clock	TBD	TBD	ns
t_{RCKH}	Input HIGH Delay for Global Clock	TBD	TBD	ns
$t_{RCKMPWH}$	Minimum Pulse Width HIGH for Global Clock			ns
$t_{RCKMPWL}$	Minimum Pulse Width LOW for Global Clock			ns
t_{RCKSW}	Maximum Skew for Global Clock		TBD	ns
F_{RMAX}	Maximum Frequency for Global Clock			MHz

Notes:

1. Value reflects minimum load. The delay is measured from the CCC output to the clock pin of a sequential element, located in a lightly loaded row (single element is connected to the global net).
2. Value reflects maximum load. The delay is measured on the clock pin of the farthest sequential element, located in a fully loaded row (all available flip-flops are connected to the global net in the row).
3. For specific junction temperature and voltage supply levels, refer to [Table 2-7 on page 2-7](#) for derating values.

Table 2-87 • AGLN015 Global Resource
Commercial-Case Conditions: $T_J = 70^\circ\text{C}$, $V_{CC} = 1.14\text{ V}$

Parameter	Description	Std.		Units
		Min. ¹	Max. ²	
t_{RCKL}	Input LOW Delay for Global Clock	TBD	TBD	ns
t_{RCKH}	Input HIGH Delay for Global Clock	TBD	TBD	ns
$t_{RCKMPWH}$	Minimum Pulse Width HIGH for Global Clock			ns
$t_{RCKMPWL}$	Minimum Pulse Width LOW for Global Clock			ns
t_{RCKSW}	Maximum Skew for Global Clock		TBD	ns
F_{RMAX}	Maximum Frequency for Global Clock			MHz

Notes:

1. Value reflects minimum load. The delay is measured from the CCC output to the clock pin of a sequential element, located in a lightly loaded row (single element is connected to the global net).
2. Value reflects maximum load. The delay is measured on the clock pin of the farthest sequential element, located in a fully loaded row (all available flip-flops are connected to the global net in the row).
3. For specific junction temperature and voltage supply levels, refer to [Table 2-7 on page 2-7](#) for derating values.

Table 2-88 • AGLN020 Global Resource
Commercial-Case Conditions: $T_J = 70^\circ\text{C}$, $V_{CC} = 1.14\text{ V}$

Parameter	Description	Std.		Units
		Min. ¹	Max. ²	
t_{RCKL}	Input LOW Delay for Global Clock	TBD	TBD	ns
t_{RCKH}	Input HIGH Delay for Global Clock	TBD	TBD	ns
$t_{RCKMPWH}$	Minimum Pulse Width HIGH for Global Clock			ns
$t_{RCKMPWL}$	Minimum Pulse Width LOW for Global Clock			ns
t_{RCKSW}	Maximum Skew for Global Clock		TBD	ns
F_{RMAX}	Maximum Frequency for Global Clock			MHz

Notes:

1. Value reflects minimum load. The delay is measured from the CCC output to the clock pin of a sequential element, located in a lightly loaded row (single element is connected to the global net).
2. Value reflects maximum load. The delay is measured on the clock pin of the farthest sequential element, located in a fully loaded row (all available flip-flops are connected to the global net in the row).
3. For specific junction temperature and voltage supply levels, refer to [Table 2-7 on page 2-7](#) for derating values.

Table 2-89 • AGLN060 Global Resource
Commercial-Case Conditions: $T_J = 70^\circ\text{C}$, $V_{CC} = 1.14\text{ V}$

Parameter	Description	Std.		Units
		Min. ¹	Max. ²	
t_{RCKL}	Input LOW Delay for Global Clock	2.02	2.49	ns
t_{RCKH}	Input HIGH Delay for Global Clock	2.09	2.72	ns
$t_{RCKMPWH}$	Minimum Pulse Width HIGH for Global Clock			ns
$t_{RCKMPWL}$	Minimum Pulse Width LOW for Global Clock			ns
t_{RCKSW}	Maximum Skew for Global Clock		0.63	ns
F_{RMAX}	Maximum Frequency for Global Clock			MHz

Notes:

1. Value reflects minimum load. The delay is measured from the CCC output to the clock pin of a sequential element, located in a lightly loaded row (single element is connected to the global net).
2. Value reflects maximum load. The delay is measured on the clock pin of the farthest sequential element, located in a fully loaded row (all available flip-flops are connected to the global net in the row).
3. For specific junction temperature and voltage supply levels, refer to [Table 2-7 on page 2-7](#) for derating values.

Table 2-90 • AGLN125 Global Resource
Commercial-Case Conditions: $T_J = 70^\circ\text{C}$, $V_{CC} = 1.14\text{ V}$

Parameter	Description	Std.		Units
		Min. ¹	Max. ²	
t_{RCKL}	Input LOW Delay for Global Clock	2.08	2.54	ns
t_{RCKH}	Input HIGH Delay for Global Clock	2.15	2.77	ns
$t_{RCKMPWH}$	Minimum Pulse Width HIGH for Global Clock			ns
$t_{RCKMPWL}$	Minimum Pulse Width LOW for Global Clock			ns
t_{RCKSW}	Maximum Skew for Global Clock		0.62	ns
F_{RMAX}	Maximum Frequency for Global Clock			MHz

Notes:

1. Value reflects minimum load. The delay is measured from the CCC output to the clock pin of a sequential element, located in a lightly loaded row (single element is connected to the global net).
2. Value reflects maximum load. The delay is measured on the clock pin of the farthest sequential element, located in a fully loaded row (all available flip-flops are connected to the global net in the row).
3. For specific junction temperature and voltage supply levels, refer to [Table 2-7 on page 2-7](#) for derating values.

Table 2-91 • AGLN250 Global Resource
Commercial-Case Conditions: $T_J = 70^\circ\text{C}$, $V_{CC} = 1.14\text{ V}$

Parameter	Description	Std.		Units
		Min. ¹	Max. ²	
t_{RCKL}	Input LOW Delay for Global Clock	2.11	2.57	ns
t_{RCKH}	Input HIGH Delay for Global Clock	2.19	2.81	ns
$t_{RCKMPWH}$	Minimum Pulse Width HIGH for Global Clock			ns
$t_{RCKMPWL}$	Minimum Pulse Width LOW for Global Clock			ns
t_{RCKSW}	Maximum Skew for Global Clock		0.62	ns
F_{RMAX}	Maximum Frequency for Global Clock			MHz

Notes:

1. Value reflects minimum load. The delay is measured from the CCC output to the clock pin of a sequential element, located in a lightly loaded row (single element is connected to the global net).
2. Value reflects maximum load. The delay is measured on the clock pin of the farthest sequential element, located in a fully loaded row (all available flip-flops are connected to the global net in the row).
3. For specific junction temperature and voltage supply levels, refer to [Table 2-7 on page 2-7](#) for derating values.

Clock Conditioning Circuits

CCC Electrical Specifications

Timing Characteristics

Table 2-92 • IGLOO nano CCC/PLL Specification
For IGLOO nano V2 or V5 devices, 1.5 V DC Core Supply Voltage

Parameter	Min.	Typ.	Max.	Units
Clock Conditioning Circuitry Input Frequency f_{IN_CCC}	1.5		250	MHz
Clock Conditioning Circuitry Output Frequency f_{OUT_CCC}	0.75		250	MHz
Delay Increments in Programmable Delay Blocks ^{1, 2}		360		ps
Number of Programmable Values in Each Programmable Delay Block			32	
Serial Clock (SCLK) for Dynamic PLL ⁵			100	
Input Cycle-to-Cycle Jitter (peak magnitude)			1	ns
CCC Output Peak-to-Peak Period Jitter F_{CCC_OUT}	Max Peak-to-Peak Period Jitter			
	1 Global Network Used	External FB Used	3 Global Networks Used	
0.75 MHz to 24 MHz	0.50%	0.75%	0.70%	
24 MHz to 100 MHz	1.00%	1.50%	1.20%	
100 MHz to 250 MHz	2.50%	3.75%	2.75%	
Acquisition Time				
LockControl = 0			300	μs
LockControl = 1			6.0	ms
Tracking Jitter				
LockControl = 0			2.5	ns
LockControl = 1			1.5	ns
Output Duty Cycle	48.5		51.5	%
Delay Range in Block: Programmable Delay 1 ^{1, 2}	1.25		15.65	ns
Delay Range in Block: Programmable Delay 2 ^{1, 2}	0.025		15.65	ns
Delay Range in Block: Fixed Delay ^{1, 2}		3.5		ns

Notes:

1. This delay is a function of voltage and temperature. See [Table 2-6 on page 2-6](#) and [Table 2-7 on page 2-7](#) for deratings.
2. $T_J = 25^\circ\text{C}$, $V_{CC} = 1.5\text{ V}$
3. The AGLN010, AGLN015, and AGLN020 devices do not support PLL.
4. Tracking jitter is defined as the variation in clock edge position of PLL outputs with reference to the PLL input clock edge. Tracking jitter does not measure the variation in PLL output period, which is covered by the period jitter parameter.
5. Maximum value obtained for a STD speed grade device in Worst-Case Commercial conditions. For specific junction temperature and voltage supply levels, refer to [Table 2-6 on page 2-6](#) and [Table 2-7 on page 2-7](#) for derating values.

Table 2-93 • IGLOO nano CCC/PLL Specification
 For IGLOO nano V2 Devices, 1.2 V DC Core Supply Voltage

Parameter	Min.	Typ.	Max.	Units
Clock Conditioning Circuitry Input Frequency f_{IN_CCC}	1.5		160	MHz
Clock Conditioning Circuitry Output Frequency f_{OUT_CCC}	0.75		160	MHz
Delay Increments in Programmable Delay Blocks ^{1, 2}		580		ps
Number of Programmable Values in Each Programmable Delay Block			32	
Serial Clock (SCLK) for Dynamic PLL ⁵			60	MHz
Input Cycle-to-Cycle Jitter (peak magnitude)			0.25	ns
CCC Output Peak-to-Peak Period Jitter F_{CCC_OUT}	Max Peak-to-Peak Period Jitter			
	1 Global Network Used	External FB Used	3 Global Networks Used	
0.75 MHz to 24 MHz	0.50%	0.75%	0.70%	
24 MHz to 100 MHz	1.00%	1.50%	1.20%	
100 MHz to 160 MHz	2.50%	3.75%	2.75%	
Acquisition Time				
	LockControl = 0		300	μ s
	LockControl = 1		6.0	ms
Tracking Jitter				
	LockControl = 0		4	ns
	LockControl = 1		3	ns
Output Duty Cycle	48.5		51.5	%
Delay Range in Block: Programmable Delay 1 ^{1, 2}	2.3		20.86	ns
Delay Range in Block: Programmable Delay 2 ^{1, 2,}	0.025		20.86	ns
Delay Range in Block: Fixed Delay ^{1, 2}		5.7		ns

Notes:

1. This delay is a function of voltage and temperature. See [Table 2-6 on page 2-6](#) and [Table 2-7 on page 2-7](#) for deratings.
2. $T_J = 25^\circ\text{C}$, $V_{CC} = 1.2\text{ V}$
3. The AGLN010, AGLN015, and AGLN020 devices do not support PLLs.
4. Tracking jitter is defined as the variation in clock edge position of PLL outputs with reference to PLL input clock edge. Tracking jitter does not measure the variation in PLL output period, which is covered by period jitter parameter.
5. Maximum value obtained for a STD speed grade device in Worst-Case Commercial conditions. For specific junction temperature and voltage supply levels, refer to [Table 2-6 on page 2-6](#) and [Table 2-7 on page 2-7](#) for derating values.

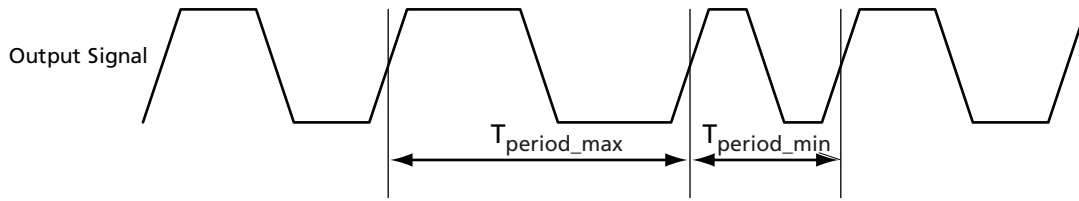

Note: Peak-to-peak jitter measurements are defined by $T_{\text{peak-to-peak}} = T_{\text{period_max}} - T_{\text{period_min}}$.

Figure 2-26 • Peak-to-Peak Jitter Definition

Embedded SRAM and FIFO Characteristics

SRAM

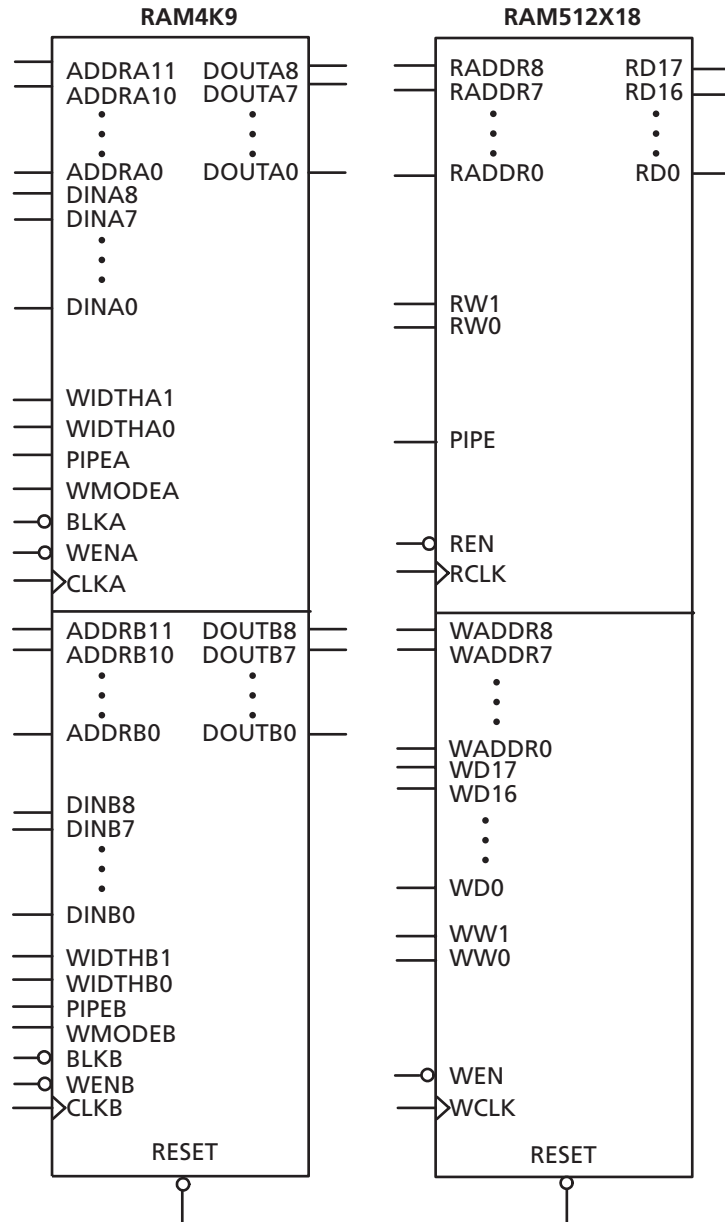

Figure 2-27 • RAM Models

Timing Waveforms

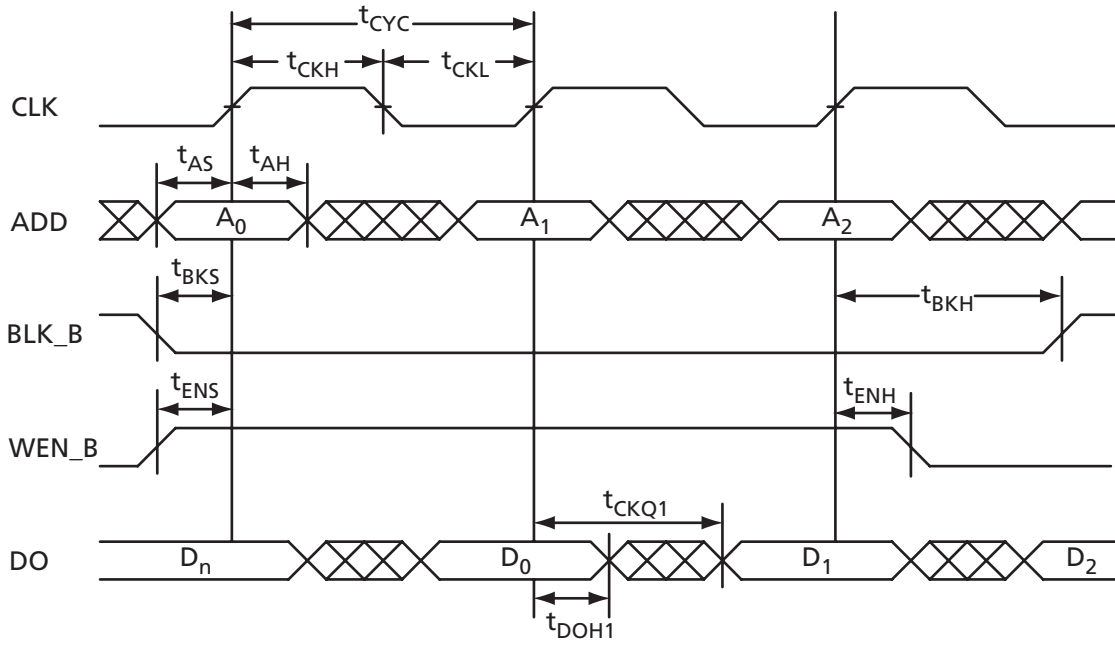

Figure 2-28 • RAM Read for Pass-Through Output

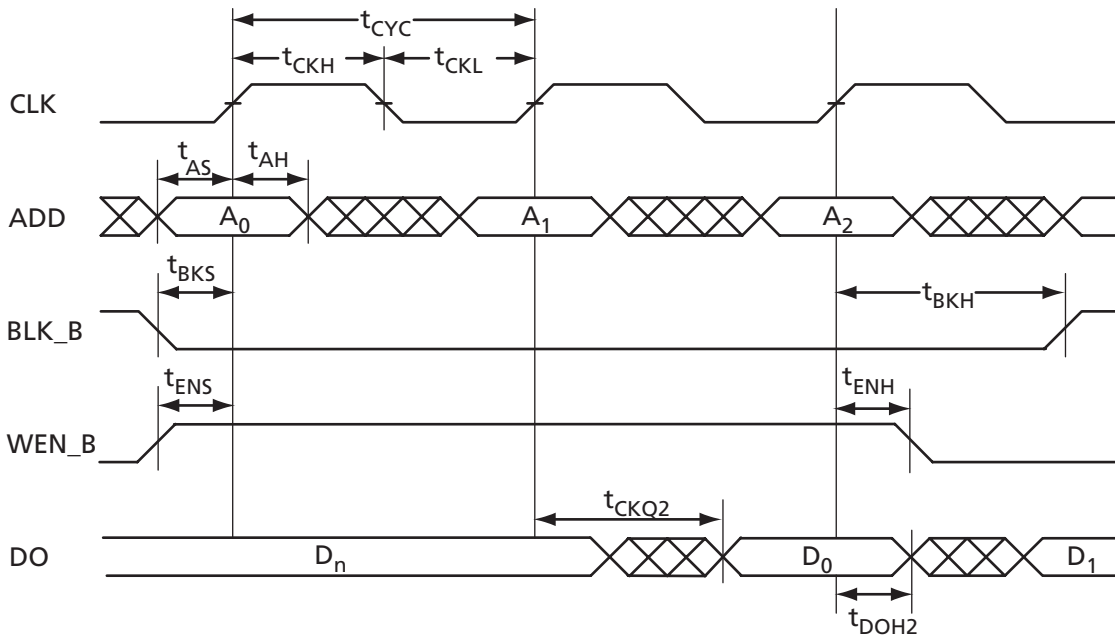
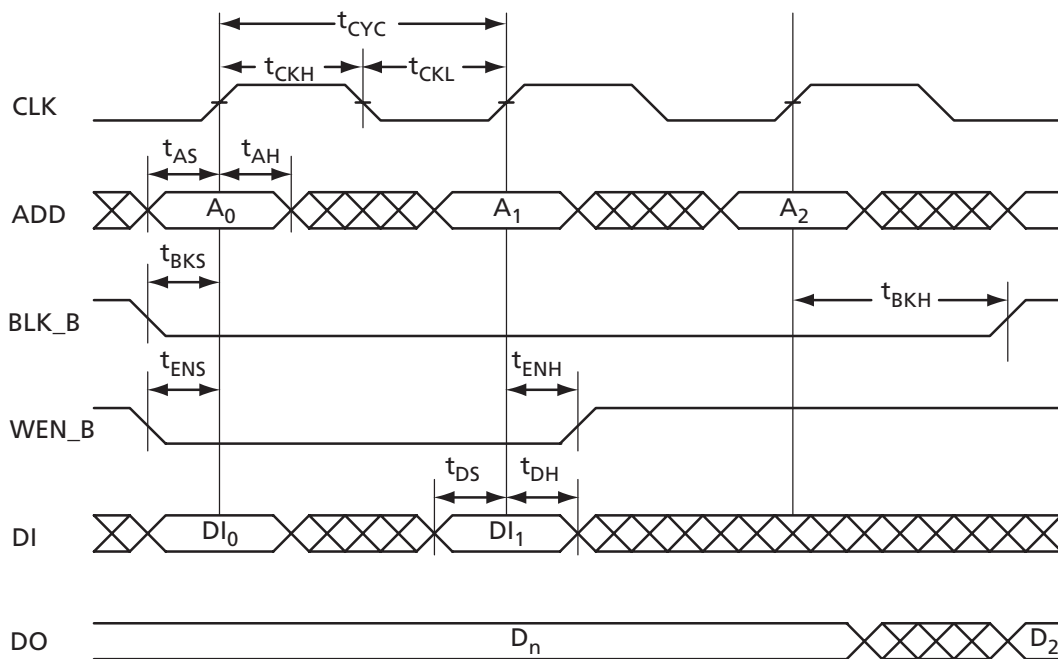
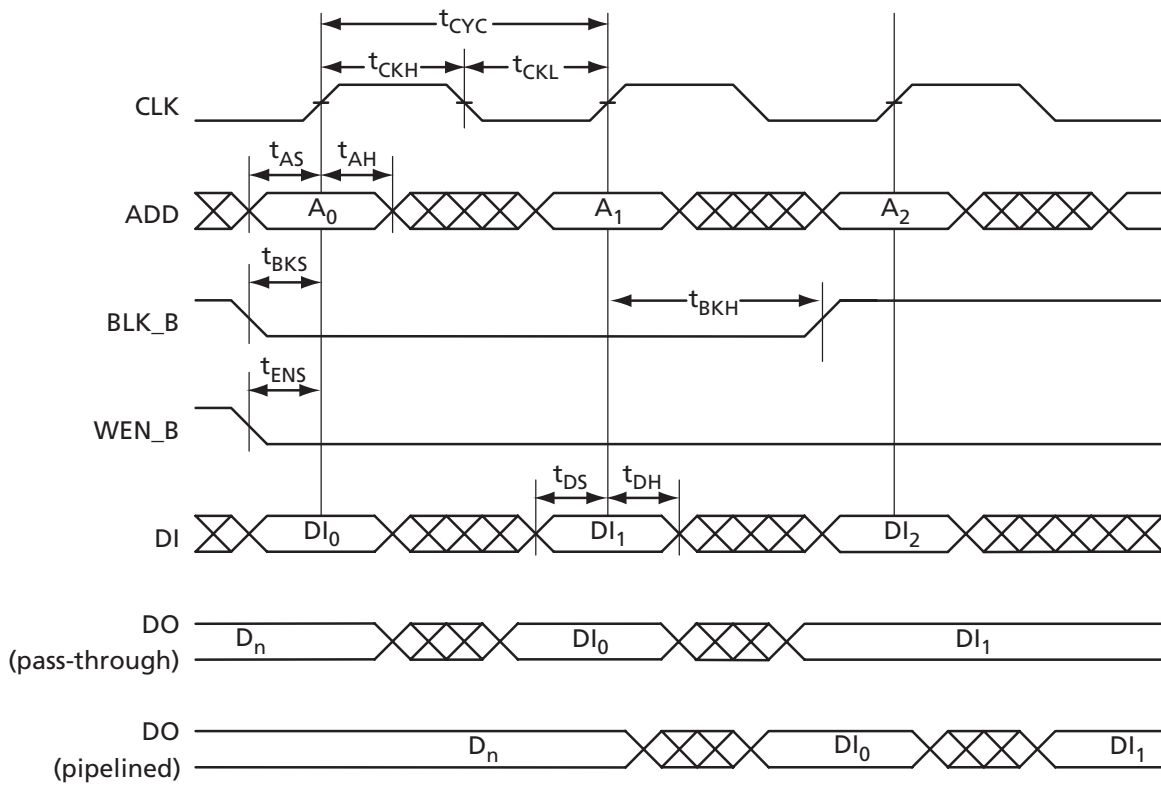

Figure 2-29 • RAM Read for Pipelined Output

Figure 2-30 • RAM Write, Output Retained (WMODE = 0)

Figure 2-31 • RAM Write, Output as Write Data (WMODE = 1)

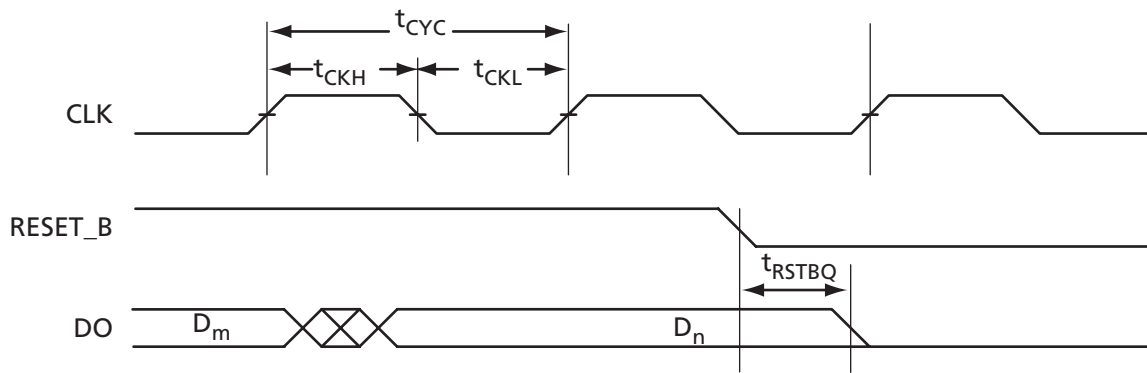

Figure 2-32 • RAM Reset

Timing Characteristics

1.5 V DC Core Voltage

Table 2-94 • RAM4K9

Commercial-Case Conditions: $T_J = 70^\circ\text{C}$, Worst-Case $V_{CC} = 1.425\text{ V}$

Parameter	Description	Std.	Units
t_{AS}	Address setup time	0.83	ns
t_{AH}	Address hold time	0.16	ns
t_{ENS}	REN_B, WEN_B setup time	0.81	ns
t_{ENH}	REN_B, WEN_B hold time	0.16	ns
t_{BKS}	BLK_B setup time	1.65	ns
t_{BKH}	BLK_B hold time	0.16	ns
t_{DS}	Input data (DI) setup time	0.71	ns
t_{DH}	Input data (DI) hold time	0.36	ns
t_{CKQ1}	Clock HIGH to new data valid on DO (output retained, WMODE = 0)	3.53	ns
	Clock HIGH to new data valid on DO (flow-through, WMODE = 1)	3.06	ns
t_{CKQ2}	Clock HIGH to new data valid on DO (pipelined)	1.81	ns
t_{C2CWWL}	Address collision clk-to-clk delay for reliable write after write on same address; applicable to closing edge	0.23	ns
t_{C2CRWH}	Address collision clk-to-clk delay for reliable read access after write on same address; applicable to opening edge	0.35	ns
t_{C2CWRH}	Address collision clk-to-clk delay for reliable write access after read on same address; applicable to opening edge	0.41	ns
t_{RSTBQ}	RESET_B LOW to data out LOW on DO (flow-through)	2.06	ns
	RESET_B LOW to data out LOW on DO (pipelined)	2.06	ns
$t_{REMRSTB}$	RESET_B removal	0.61	ns
$t_{RECRSTB}$	RESET_B recovery	3.21	ns
$t_{MPWRSTB}$	RESET_B minimum pulse width	0.68	ns
t_{CYC}	Clock cycle time	6.24	ns
F_{MAX}	Maximum frequency	160	MHz

Note: For specific junction temperature and voltage supply levels, refer to Table 2-6 on page 2-6 for derating values.

Table 2-95 • RAM512X18
Commercial-Case Conditions: $T_J = 70^\circ\text{C}$, Worst-Case $V_{CC} = 1.425\text{ V}$

Parameter	Description	Std.	Units
t_{AS}	Address setup time	0.83	ns
t_{AH}	Address hold time	0.16	ns
t_{ENS}	REN_B, WEN_B setup time	0.73	ns
t_{ENH}	REN_B, WEN_B hold time	0.08	ns
t_{DS}	Input data (DI) setup time	0.71	ns
t_{DH}	Input data (DI) hold time	0.36	ns
t_{CKQ1}	Clock HIGH to new data valid on DO (output retained, WMODE = 0)	4.21	ns
t_{CKQ2}	Clock HIGH to new data valid on DO (pipelined)	1.71	ns
t_{C2CRWH}	Address collision clk-to-clk delay for reliable read access after write on same address; applicable to opening edge	0.35	ns
t_{C2CWRH}	Address collision clk-to-clk delay for reliable write access after read on same address; applicable to opening edge	0.42	ns
t_{RSTBQ}	RESET_B LOW to data out LOW on DO (flow-through)	2.06	ns
	RESET_B LOW to data out LOW on DO (pipelined)	2.06	ns
$t_{REMRSTB}$	RESET_B removal	0.61	ns
$t_{RECRSTB}$	RESET_B recovery	3.21	ns
$t_{MPWRSTB}$	RESET_B minimum pulse width	0.68	ns
t_{CYC}	Clock cycle time	6.24	ns
F_{MAX}	Maximum frequency	160	MHz

Note: For specific junction temperature and voltage supply levels, refer to Table 2-6 on page 2-6 for derating values.

1.2 V DC Core Voltage

Table 2-96 • RAM4K9

Commercial-Case Conditions: $T_J = 70^\circ\text{C}$, Worst-Case $V_{CC} = 1.14\text{ V}$

Parameter	Description	Std.	Units
t_{AS}	Address setup time	1.53	ns
t_{AH}	Address hold time	0.29	ns
t_{ENS}	REN_B, WEN_B setup time	1.50	ns
t_{ENH}	REN_B, WEN_B hold time	0.29	ns
t_{BKS}	BLK_B setup time	3.05	ns
t_{BKH}	BLK_B hold time	0.29	ns
t_{DS}	Input data (DI) setup time	1.33	ns
t_{DH}	Input data (DI) hold time	0.66	ns
t_{CKQ1}	Clock HIGH to new data valid on DO (output retained, WMODE = 0)	6.61	ns
	Clock HIGH to new data valid on DO (flow-through, WMODE = 1)	5.72	ns
t_{CKQ2}	Clock HIGH to new data valid on DO (pipelined)	3.38	ns
t_{C2CWWL}	Address collision clk-to-clk delay for reliable write after write on same address; applicable to closing edge	0.30	ns
t_{C2CRWH}	Address collision clk-to-clk delay for reliable read access after write on same address; applicable to opening edge	0.89	ns
t_{C2CWRH}	Address collision clk-to-clk delay for reliable write access after read on same address; applicable to opening edge	1.01	ns
t_{RSTBQ}	RESET_B LOW to data out LOW on DO (flow-through)	3.86	ns
	RESET_B LOW to data out LOW on DO (pipelined)	3.86	ns
$t_{REMRSTB}$	RESET_B removal	1.12	ns
$t_{RECRSTB}$	RESET_B recovery	5.93	ns
$t_{MPWRSTB}$	RESET_B minimum pulse width	1.18	ns
t_{CYC}	Clock cycle time	10.90	ns
F_{MAX}	Maximum frequency	92	MHz

Note: For specific junction temperature and voltage supply levels, refer to Table 2-7 on page 2-7 for derating values.

Table 2-97 • RAM512X18
Commercial-Case Conditions: $T_J = 70^\circ\text{C}$, Worst-Case $V_{CC} = 1.14\text{ V}$

Parameter	Description	Std.	Units
t_{AS}	Address setup time	1.53	ns
t_{AH}	Address hold time	0.29	ns
t_{ENS}	REN_B, WEN_B setup time	1.36	ns
t_{ENH}	REN_B, WEN_B hold time	0.15	ns
t_{DS}	Input data (DI) setup time	1.33	ns
t_{DH}	Input data (DI) hold time	0.66	ns
t_{CKQ1}	Clock HIGH to new data valid on DO (output retained, WMODE = 0)	7.88	ns
t_{CKQ2}	Clock HIGH to new data valid on DO (pipelined)	3.20	ns
t_{C2CRWH}	Address collision clk-to-clk delay for reliable read access after write on same address; applicable to opening edge	0.87	ns
t_{C2CWRH}	Address collision clk-to-clk delay for reliable write access after read on same address; applicable to opening edge	1.04	ns
t_{RSTBQ}	RESET_B LOW to data out LOW on DO (flow through)	3.86	ns
	RESET_B LOW to data out LOW on DO (pipelined)	3.86	ns
$t_{REMRSTB}$	RESET_B removal	1.12	ns
$t_{RECRSTB}$	RESET_B recovery	5.93	ns
$t_{MPWRSTB}$	RESET_B minimum pulse width	1.18	ns
t_{CYC}	Clock cycle time	10.90	ns
F_{MAX}	Maximum frequency	92	MHz

Note: For specific junction temperature and voltage supply levels, refer to [Table 2-7 on page 2-7](#) for derating values.

FIFO

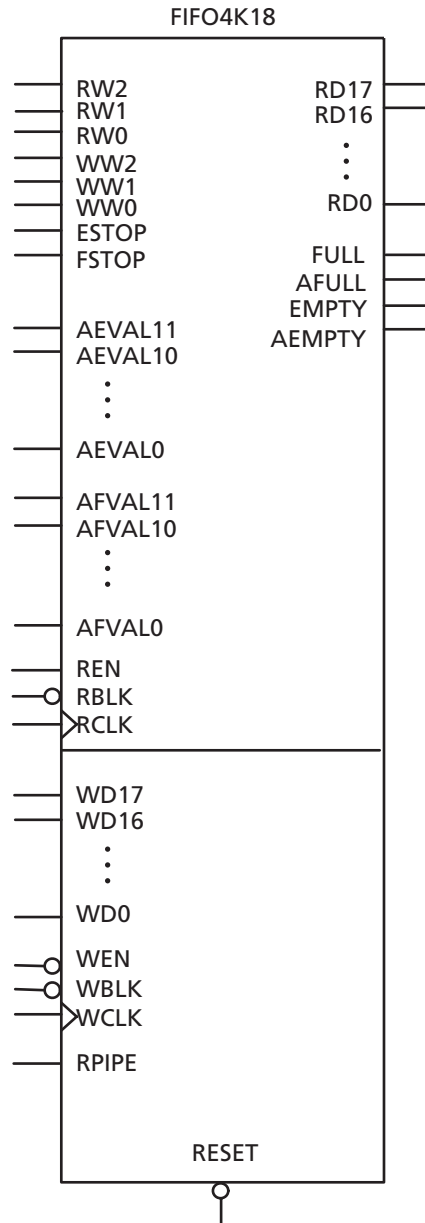

Figure 2-33 • FIFO Model

Timing Waveforms

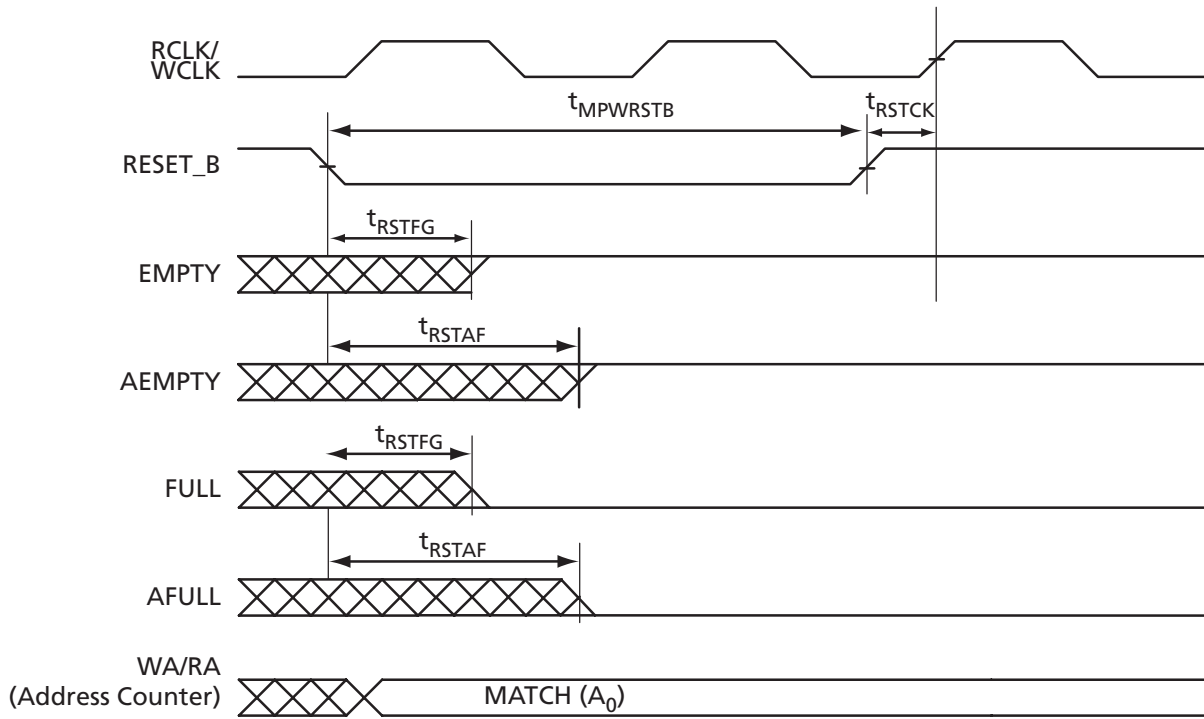

Figure 2-34 • FIFO Reset

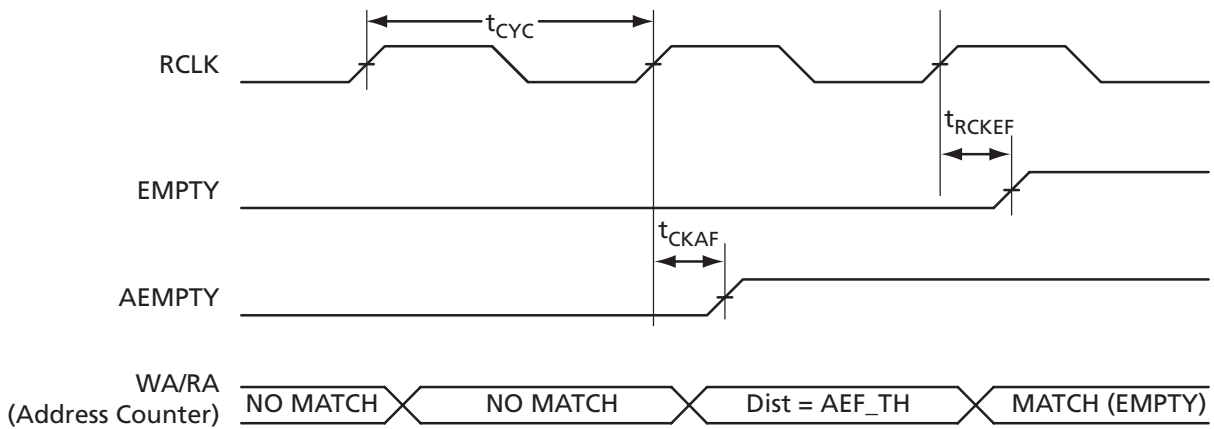
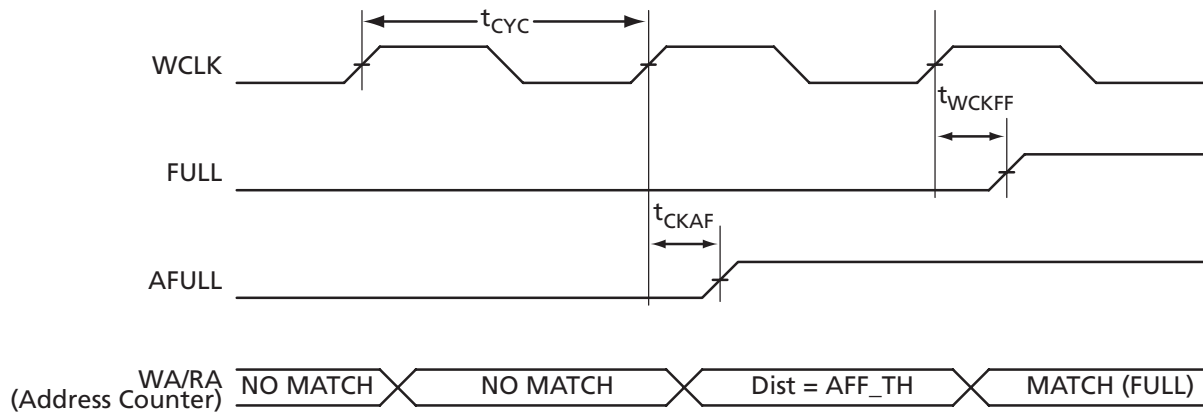
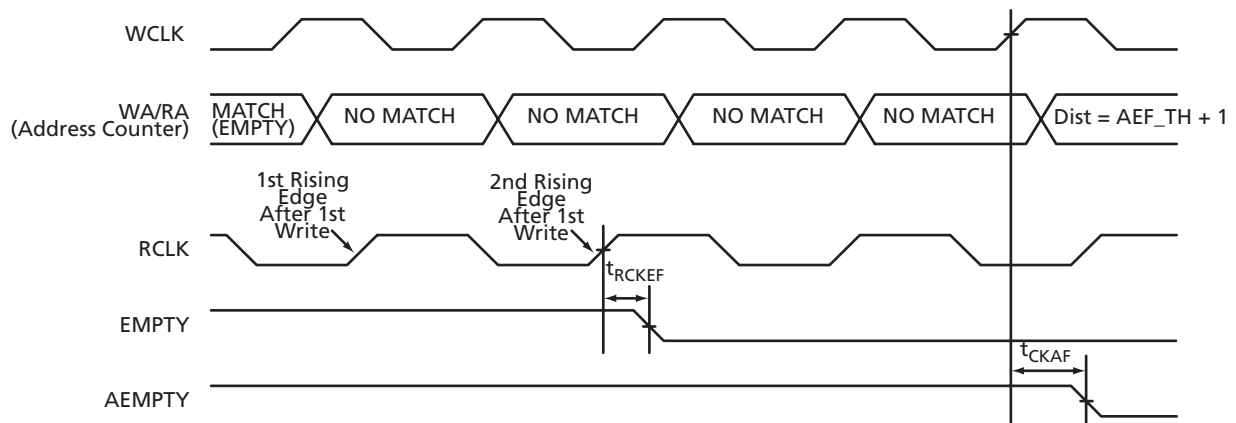
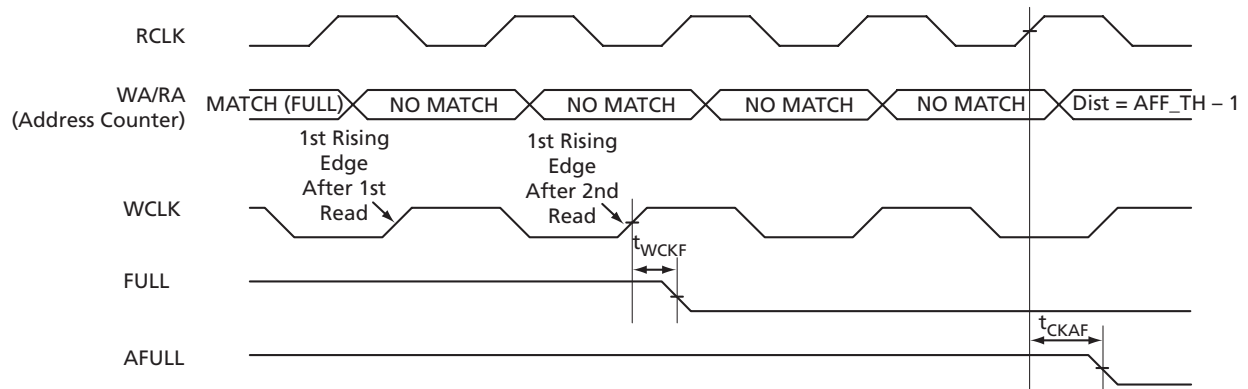

Figure 2-35 • FIFO EMPTY Flag and AEMPTY Flag Assertion

Figure 2-36 • FIFO FULL Flag and AFULL Flag Assertion

Figure 2-37 • FIFO EMPTY Flag and AEMPTY Flag Deassertion

Figure 2-38 • FIFO FULL Flag and AFULL Flag Deassertion

Timing Characteristics**1.5 V DC Core Voltage****Table 2-98 • FIFO****Worst Commercial-Case Conditions: $T_J = 70^\circ\text{C}$, $V_{CC} = 1.425\text{ V}$**

Parameter	Description	Std.	Units
t_{ENS}	REN_B, WEN_B Setup Time	1.99	ns
t_{ENH}	REN_B, WEN_B Hold Time	0.16	ns
t_{BKS}	BLK_B Setup Time	0.30	ns
t_{BKH}	BLK_B Hold Time	0.00	ns
t_{DS}	Input Data (DI) Setup Time	0.76	ns
t_{DH}	Input Data (DI) Hold Time	0.25	ns
t_{CKQ1}	Clock HIGH to New Data Valid on DO (flow-through)	3.33	ns
t_{CKQ2}	Clock HIGH to New Data Valid on DO (pipelined)	1.80	ns
t_{RCKEF}	RCLK HIGH to Empty Flag Valid	3.53	ns
t_{WCKFF}	WCLK HIGH to Full Flag Valid	3.35	ns
t_{CKAF}	Clock HIGH to Almost Empty/Full Flag Valid	12.85	ns
t_{RSTFG}	RESET_B LOW to Empty/Full Flag Valid	3.48	ns
t_{RSTAF}	RESET_B LOW to Almost Empty/Full Flag Valid	12.72	ns
t_{RSTBQ}	RESET_B LOW to Data Out LOW on DO (flow-through)	2.02	ns
	RESET_B LOW to Data Out LOW on DO (pipelined)	2.02	ns
$t_{REMRSTB}$	RESET_B Removal	0.61	ns
$t_{RECRSTB}$	RESET_B Recovery	3.21	ns
$t_{MPWRSTB}$	RESET_B Minimum Pulse Width	0.68	ns
t_{CYC}	Clock Cycle Time	6.24	ns
F_{MAX}	Maximum Frequency for FIFO	160	MHz

Note: For specific junction temperature and voltage supply levels, refer to Table 2-6 on page 2-6 for derating values.

1.2 V DC Core Voltage

Table 2-99 • FIFO

Worst Commercial-Case Conditions: $T_J = 70^\circ\text{C}$, $V_{CC} = 1.14\text{ V}$

Parameter	Description	Std.	Units
t_{ENS}	REN_B, WEN_B Setup Time	4.13	ns
t_{ENH}	REN_B, WEN_B Hold Time	0.31	ns
t_{BKS}	BLK_B Setup Time	0.30	ns
t_{BKH}	BLK_B Hold Time	0.00	ns
t_{DS}	Input Data (DI) Setup Time	1.56	ns
t_{DH}	Input Data (DI) Hold Time	0.49	ns
t_{CKQ1}	Clock HIGH to New Data Valid on DO (flow-through)	6.80	ns
t_{CKQ2}	Clock HIGH to New Data Valid on DO (pipelined)	3.62	ns
t_{RCKEF}	RCLK HIGH to Empty Flag Valid	7.23	ns
t_{WCKFF}	WCLK HIGH to Full Flag Valid	6.85	ns
t_{CKAF}	Clock HIGH to Almost Empty/Full Flag Valid	26.61	ns
t_{RSTFG}	RESET_B LOW to Empty/Full Flag Valid	7.12	ns
t_{RSTAF}	RESET_B LOW to Almost Empty/Full Flag Valid	26.33	ns
t_{RSTBQ}	RESET_B LOW to Data Out LOW on DO (flow-through)	4.09	ns
	RESET_B LOW to Data Out LOW on DO (pipelined)	4.09	ns
$t_{REMRSTB}$	RESET_B Removal	1.23	ns
$t_{RECRSTB}$	RESET_B Recovery	6.58	ns
$t_{MPWRSTB}$	RESET_B Minimum Pulse Width	1.18	ns
t_{CYC}	Clock Cycle Time	10.90	ns
F_{MAX}	Maximum Frequency for FIFO	92	MHz

Note: For specific junction temperature and voltage supply levels, refer to [Table 2-7 on page 2-7](#) for derating values.

Embedded FlashROM Characteristics

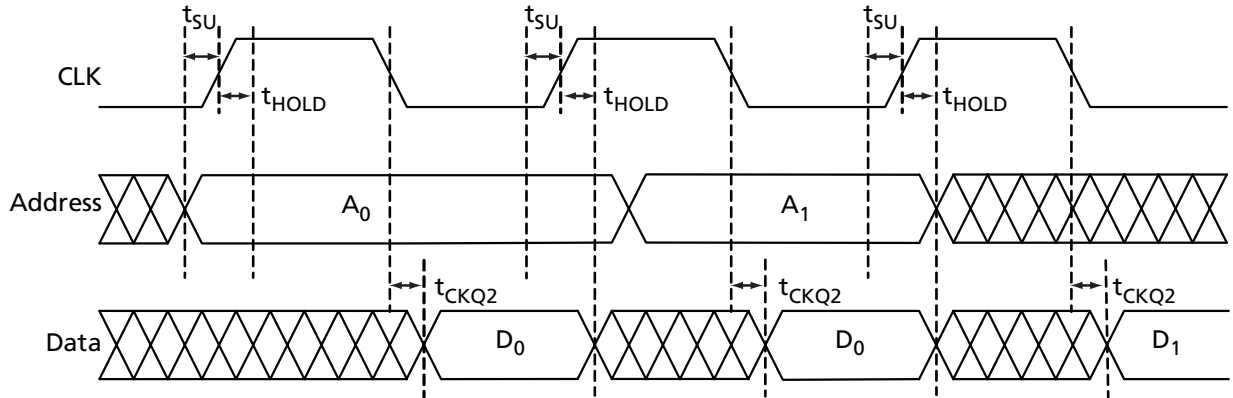

Figure 2-39 • Timing Diagram

Timing Characteristics

1.5 V DC Core Voltage

Table 2-100 • Embedded FlashROM Access Time

Worst Commercial-Case Conditions: T_J = 70°C, V_{CC} = 1.425 V

Parameter	Description	Std.	Units
t _{SU}	Address Setup Time	0.57	ns
t _{HOLD}	Address Hold Time	0.00	ns
t _{CK2Q}	Clock to Out	20.90	ns
F _{MAX}	Maximum Clock Frequency	15	MHz

1.2 V DC Core Voltage

Table 2-101 • Embedded FlashROM Access Time

Worst Commercial-Case Conditions: T_J = 70°C, V_{CC} = 1.14 V

Parameter	Description	Std.	Units
t _{SU}	Address Setup Time	0.59	ns
t _{HOLD}	Address Hold Time	0.00	ns
t _{CK2Q}	Clock to Out	35.74	ns
F _{MAX}	Maximum Clock Frequency	10	MHz

JTAG 1532 Characteristics

JTAG timing delays do not include JTAG I/Os. To obtain complete JTAG timing, add I/O buffer delays to the corresponding standard selected; refer to the I/O timing characteristics in the "User I/O Characteristics" section on page 2-15 for more details.

Timing Characteristics

1.5 V DC Core Voltage

Table 2-102 • JTAG 1532

Commercial-Case Conditions: $T_J = 70^\circ\text{C}$, Worst-Case $V_{CC} = 1.425\text{ V}$

Parameter	Description	Std.	Units
t_{DISU}	Test Data Input Setup Time	1.00	ns
t_{DIHD}	Test Data Input Hold Time	2.00	ns
t_{TMSSU}	Test Mode Select Setup Time	1.00	ns
t_{TMDHD}	Test Mode Select Hold Time	2.00	ns
t_{TCK2Q}	Clock to Q (data out)	8.00	ns
t_{RSTB2Q}	Reset to Q (data out)	25.00	ns
F_{TCKMAX}	TCK Maximum Frequency	15	MHz
$t_{TRSTREM}$	ResetB Removal Time	0.58	ns
$t_{TRSTREC}$	ResetB Recovery Time	0.00	ns
$t_{TRSTMPW}$	ResetB Minimum Pulse	TBD	ns

Note: For specific junction temperature and voltage supply levels, refer to [Table 2-6 on page 2-6](#) for derating values.

1.2 V DC Core Voltage

Table 2-103 • JTAG 1532

Commercial-Case Conditions: $T_J = 70^\circ\text{C}$, Worst-Case $V_{CC} = 1.14\text{ V}$

Parameter	Description	Std.	Units
t_{DISU}	Test Data Input Setup Time	1.50	ns
t_{DIHD}	Test Data Input Hold Time	3.00	ns
t_{TMSSU}	Test Mode Select Setup Time	1.50	ns
t_{TMDHD}	Test Mode Select Hold Time	3.00	ns
t_{TCK2Q}	Clock to Q (data out)	11.00	ns
t_{RSTB2Q}	Reset to Q (data out)	30.00	ns
F_{TCKMAX}	TCK Maximum Frequency	9.00	MHz
$t_{TRSTREM}$	ResetB Removal Time	1.18	ns
$t_{TRSTREC}$	ResetB Recovery Time	0.00	ns
$t_{TRSTMPW}$	ResetB Minimum Pulse	TBD	ns

Note: For specific junction temperature and voltage supply levels, refer to [Table 2-6 on page 2-6](#) for derating values.

Part Number and Revision Date

Part Number 51700110-002-1
Revised November 2008

List of Changes

The following table lists critical changes that were made in the current version of the chapter.

Previous Version	Changes in Current Version (Advance v0.2)	Page
Advance v0.1 (October 2008)	The table notes and references were revised in Table 2-2 · Recommended Operating Conditions ¹ . VMV was included with V _{CCI} and a table note was added stating, "VMV pins must be connected to the corresponding V _{CCI} pins. See <i>Pin Descriptions</i> for further information." Please review carefully.	2-2
	V _{JTAG} was added to the list in the table note for Table 2-8 · Quiescent Supply Current (I_{DD}) Characteristics, IGLOO nano Flash*Freeze Mode* . Values were added for AGLN010, AGLN015, and AGLN030 for 1.5 V.	2-7
	V _{CCI} was removed from the list in the table note for Table 2-9 · Quiescent Supply Current (I_{DD}) Characteristics, IGLOO nano Sleep Mode (VCC = 0 V)* .	2-7
	Values for I _{CCA} current were updated for AGLN010, AGLN015, and AGLN030 in Table 2-11 · Quiescent Supply Current (I_{DD}), No IGLOO nano Flash*Freeze Mode ¹ .	2-8
	Values for PAC1 and PAC2 were added to Table 2-14 · Different Components Contributing to Dynamic Power Consumption in IGLOO nano Devices and Table 2-16 · Different Components Contributing to Dynamic Power Consumption in IGLOO nano Devices .	2-10, 2-11
	Table notes regarding wide range support were added to Table 2-20 · Summary of Maximum and Minimum DC Input and Output Levels .	2-19
	1.2 V LVCMOS wide range values were added to Table 2-21 · Summary of Maximum and Minimum DC Input Levels and Table 2-22 · Summary of AC Measuring Points .	2-19, 2-20
	The following table note was added to Table 2-24 · Summary of I/O Timing Characteristics—Software Default Settings and Table 2-25 · Summary of I/O Timing Characteristics—Software Default Settings : "All LVCMOS 3.3 V software macros support LVCMOS 3.3 V wide range, as specified in the JESD8-B specification."	2-21
3.3 V LVCMOS Wide Range and 1.2 V Wide Range were added to Table 2-27 · I/O Output Buffer Maximum Resistances ¹ and Table 2-29 · I/O Short Currents IOSH/IOSL .	2-22, 2-23	

Actel Safety Critical, Life Support, and High-Reliability Applications Policy

The Actel products described in this advance status datasheet may not have completed Actel's qualification process. Actel may amend or enhance products during the product introduction and qualification process, resulting in changes in device functionality or performance. It is the responsibility of each customer to ensure the fitness of any Actel product (but especially a new product) for a particular purpose, including appropriateness for safety-critical, life-support, and other high-reliability applications. Consult Actel's Terms and Conditions for specific liability exclusions relating to life-support applications. A reliability report covering all of Actel's products is available on the Actel website at http://www.actel.com/documents/ORT_Report.pdf. Actel also offers a variety of enhanced qualification and lot acceptance screening procedures. Contact your local Actel sales office for additional reliability information.



3 – Package Pin Assignments

36-Pin UC

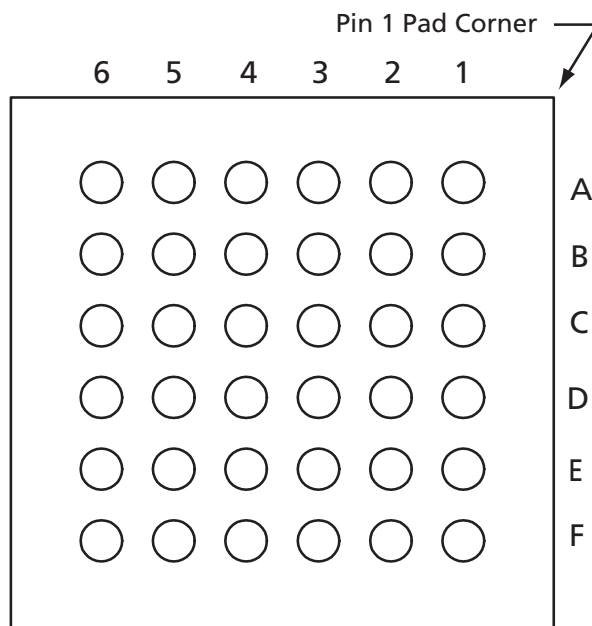

Note: This is the bottom view of the package.

Figure 3-1 •

Note

For Package Manufacturing and Environmental information, visit the Resource Center at <http://www.actel.com/products/solutions/package/docs.aspx>.

36-Pin UC	
Pin Number	AGLN010 Function
A1	IO21RSB1
A2	IO18RSB1
A3	IO13RSB1
A4	GDC0/IO00RSB0
A5	IO06RSB0
A6	GDA0/IO04RSB0
B1	GEC0/IO37RSB1
B2	IO20RSB1
B3	IO15RSB1
B4	IO09RSB0
B5	IO08RSB0
B6	IO07RSB0
C1	IO22RSB1
C2	GEA0/IO34RSB1
C3	GND
C4	GND
C5	V _{CC1} B0
C6	IO02RSB0
D1	IO33RSB1
D2	V _{CC1} B1
D3	V _{CC}
D4	V _{CC}
D5	IO10RSB0
D6	IO11RSB0
E1	IO32RSB1
E2	FF/IO31RSB1
E3	TCK
E4	V _{PUMP}
E5	TRST
E6	V _{JTAG}
F1	IO29RSB1
F2	IO25RSB1
F3	IO23RSB1
F4	TDI
F5	TMS
F6	TDO



81-Pin UC

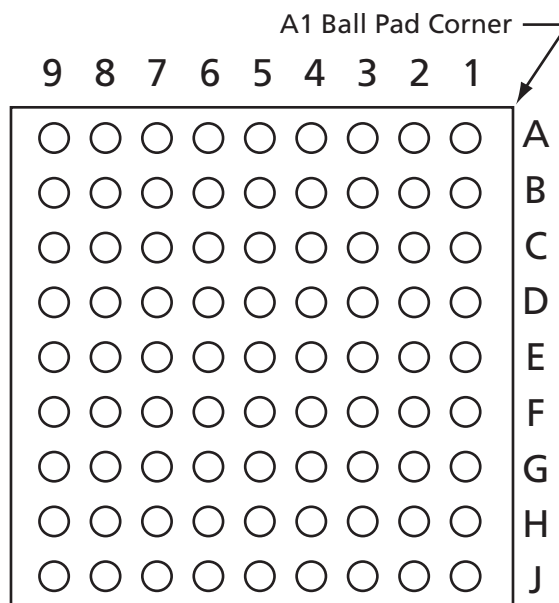

Note: This is the bottom view of the package.

Figure 3-2 •

Note

For Package Manufacturing and Environmental information, visit the Resource Center at <http://www.actel.com/products/solutions/package/docs.aspx>.

Pin Assignments

Pin assignments for the 81-Pin UC package will be published in a future version of this document.

81-Pin CS

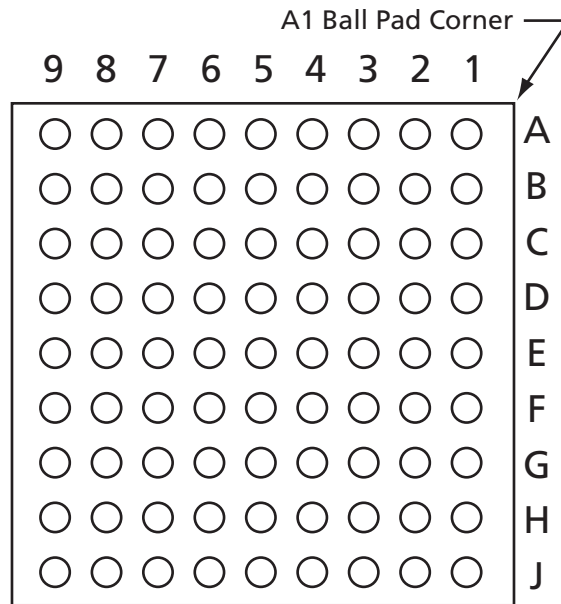

Note: This is the bottom view of the package.

Figure 3-3 •

Note

For Package Manufacturing and Environmental information, visit the Resource Center at <http://www.actel.com/products/solutions/package/docs.aspx>.

Pin Assignments

Pin assignments for the 81-Pin CS package will be published in a future version of this document.

48-Pin QFN

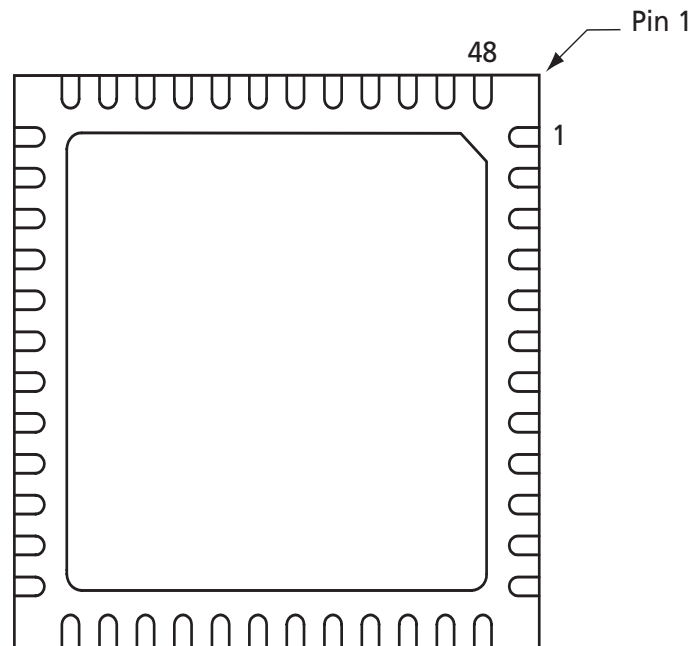

Notes:

1. This is the bottom view of the package.
2. The die attach paddle of the package is tied to ground (GND).

Figure 3-4 •

Note

For Package Manufacturing and Environmental information, visit the Resource Center at <http://www.actel.com/products/solutions/package/docs.aspx>.

48-Pin QFN	
Pin Number	AGLN010 Function
1	GEC0/IO37RSB1
2	IO36RSB1
3	GEA0/IO34RSB1
4	IO22RSB1
5	GND
6	V _{CC} B1
7	IO24RSB1
8	IO33RSB1
9	IO26RSB1
10	IO32RSB1
11	IO27RSB1
12	IO29RSB1
13	IO30RSB1
14	FF/IO31RSB1
15	IO28RSB1
16	IO25RSB1
17	IO23RSB1
18	V _{CC}
19	V _{CC} B1
20	IO17RSB1
21	IO14RSB1
22	TCK
23	TDI
24	TMS
25	V _{PUMP}
26	TDO
27	TRST
28	V _{JTAG}
29	IO11RSB0
30	IO10RSB0
31	IO09RSB0
32	IO08RSB0
33	V _{CC} B0
34	GND
35	V _{CC}
36	IO07RSB0

48-Pin QFN	
Pin Number	AGLN010 Function
37	IO06RSB0
38	GDA0/IO05RSB0
39	IO03RSB0
40	GDC0/IO01RSB0
41	IO12RSB1
42	IO13RSB1
43	IO15RSB1
44	IO16RSB1
45	IO18RSB1
46	IO19RSB1
47	IO20RSB1
48	IO21RSB1

68-Pin QFN

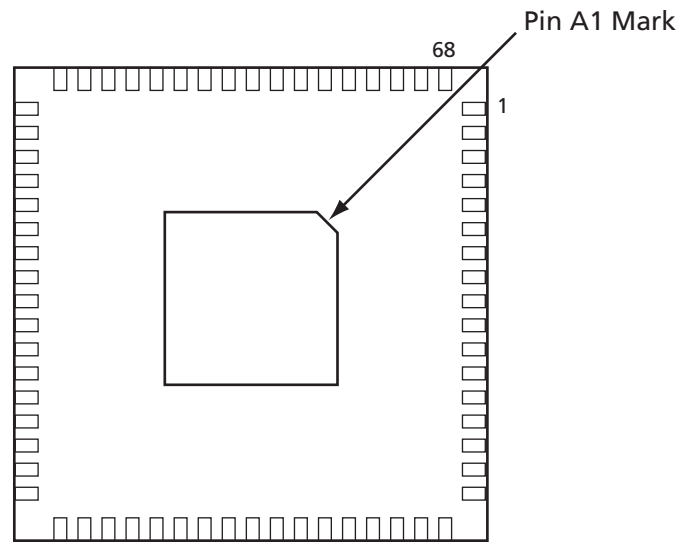

Notes:

1. This is the bottom view of the package.
2. The die attach paddle of the package is tied to ground (GND).

Figure 3-5 •

Note

For Package Manufacturing and Environmental information, visit the Resource Center at <http://www.actel.com/products/solutions/package/docs.aspx>.

68-Pin QFN	
Pin Number	AGLN015 Function
1	IO60RSB2
2	IO54RSB2
3	IO52RSB2
4	IO50RSB2
5	IO49RSB2
6	GEC0/IO48RSB2
7	GEA0/IO47RSB2
8	V _{CC}
9	GND
10	V _{CC} B2
11	IO46RSB2
12	IO45RSB2
13	IO44RSB2
14	IO43RSB2
15	IO42RSB2
16	IO41RSB2
17	IO40RSB2
18	FF/IO39RSB1
19	IO37RSB1
20	IO35RSB1
21	IO33RSB1
22	IO31RSB1
23	IO30RSB1
24	V _{CC}
25	GND
26	V _{CC} B1
27	IO27RSB1
28	IO25RSB1
29	IO23RSB1
30	IO21RSB1
31	IO19RSB1
32	TCK
33	TDI
34	TMS
35	V _{PUMP}
36	TDO

68-Pin QFN	
Pin Number	AGLN015 Function
37	TRST
38	V _{JTAG}
39	IO17RSB0
40	IO16RSB0
41	GDA0/IO15RSB0
42	GDC0/IO14RSB0
43	IO13RSB0
44	V _{CC} B0
45	GND
46	V _{CC}
47	IO12RSB0
48	IO11RSB0
49	IO09RSB0
50	IO05RSB0
51	IO00RSB0
52	IO07RSB0
53	IO03RSB0
54	IO18RSB1
55	IO20RSB1
56	IO22RSB1
57	IO24RSB1
58	IO28RSB1
59	NC
60	GND
61	NC
62	IO32RSB1
63	IO34RSB1
64	IO36RSB1
65	IO61RSB2
66	IO58RSB2
67	IO56RSB2
68	IO63RSB2

68-Pin QFN	
Pin Number	AGLN020 Function
1	IO60RSB2
2	IO54RSB2
3	IO52RSB2
4	IO50RSB2
5	IO49RSB2
6	GEC0/IO48RSB2
7	GEA0/IO47RSB2
8	V _{CC}
9	GND
10	V _{CC} B2
11	IO46RSB2
12	IO45RSB2
13	IO44RSB2
14	IO43RSB2
15	IO42RSB2
16	IO41RSB2
17	IO40RSB2
18	FF/IO39RSB1
19	IO37RSB1
20	IO35RSB1
21	IO33RSB1
22	IO31RSB1
23	IO30RSB1
24	V _{CC}
25	GND
26	V _{CC} B1
27	IO27RSB1
28	IO25RSB1
29	IO23RSB1
30	IO21RSB1
31	IO19RSB1
32	TCK
33	TDI
34	TMS
35	V _{PUMP}
36	TDO

68-Pin QFN	
Pin Number	AGLN020 Function
37	TRST
38	V _{JTAG}
39	IO17RSB0
40	IO16RSB0
41	GDA0/IO15RSB0
42	GDC0/IO14RSB0
43	IO13RSB0
44	V _{CC} B0
45	GND
46	V _{CC}
47	IO12RSB0
48	IO11RSB0
49	IO09RSB0
50	IO05RSB0
51	IO00RSB0
52	IO07RSB0
53	IO03RSB0
54	IO18RSB1
55	IO20RSB1
56	IO22RSB1
57	IO24RSB1
58	IO28RSB1
59	NC
60	GND
61	NC
62	IO32RSB1
63	IO34RSB1
64	IO36RSB1
65	IO61RSB2
66	IO58RSB2
67	IO56RSB2
68	IO63RSB2

100-Pin QFN

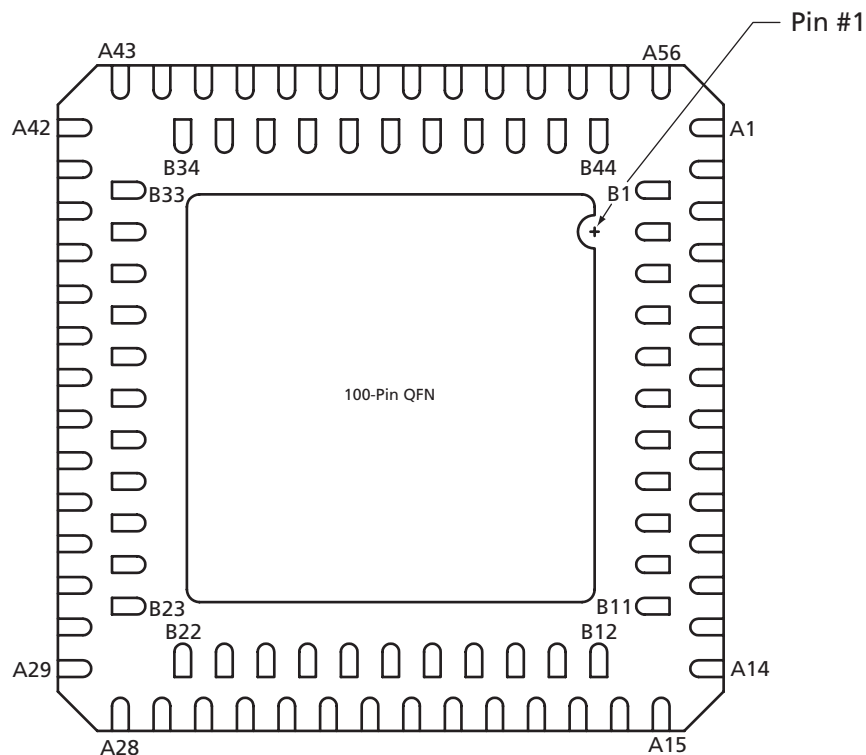

Notes:

1. This is the bottom view of the package.
2. The die attach paddle of the package is tied to ground (GND).

Figure 3-6 •

Note

For Package Manufacturing and Environmental information, visit the Resource Center at <http://www.actel.com/products/solutions/package/docs.aspx>.

Pin Assignments

Pin assignments for the 100-Pin QFN package will be published in a future version of this document.

100-Pin VQFP

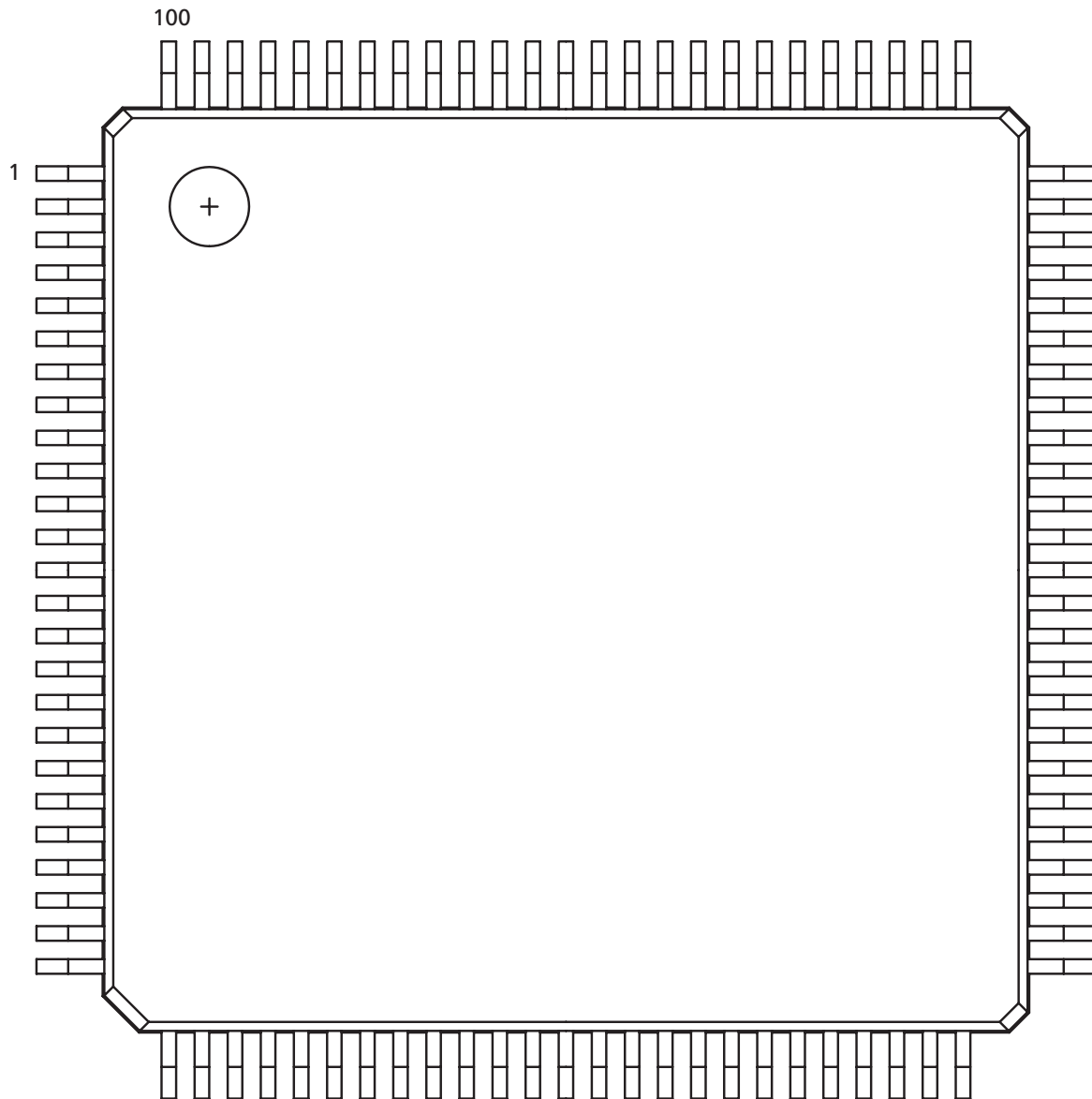

Note: This is the top view of the package.

Figure 3-7 •

Note

For Package Manufacturing and Environmental information, visit the Resource Center at <http://www.actel.com/products/solutions/package/docs.aspx>.

100-Pin VQFP		100-Pin VQFP		100-Pin VQFP	
Pin Number	AGLN060 Function	Pin Number	AGLN060 Function	Pin Number	AGLN060 Function
1	GND	37	V _{CC}	73	GBA2/IO25RSB0
2	GAA2/IO51RSB1	38	GND	74	VMV0
3	IO52RSB1	39	V _{CC} B1	75	GNDQ
4	GAB2/IO53RSB1	40	IO60RSB1	76	GBA1/IO24RSB0
5	IO95RSB1	41	IO59RSB1	77	GBA0/IO23RSB0
6	GAC2/IO94RSB1	42	IO58RSB1	78	GBB1/IO22RSB0
7	IO93RSB1	43	IO57RSB1	79	GBB0/IO21RSB0
8	IO92RSB1	44	GDC2/IO56RSB1	80	GBC1/IO20RSB0
9	GND	45	GDB2/IO55RSB1	81	GBC0/IO19RSB0
10	GFB1/IO87RSB1	46	GDA2/IO54RSB1	82	IO18RSB0
11	GFB0/IO86RSB1	47	TCK	83	IO17RSB0
12	V _{COMPLF}	48	TDI	84	IO15RSB0
13	GFA0/IO85RSB1	49	TMS	85	IO13RSB0
14	V _{CCPLF}	50	VMV1	86	IO11RSB0
15	GFA1/IO84RSB1	51	GND	87	V _{CC} B0
16	GFA2/IO83RSB1	52	V _{PUMP}	88	GND
17	V _{CC}	53	NC	89	V _{CC}
18	V _{CC} B1	54	TDO	90	IO10RSB0
19	GEC1/IO77RSB1	55	TRST	91	IO09RSB0
20	GEB1/IO75RSB1	56	V _{JTAG}	92	IO08RSB0
21	GEB0/IO74RSB1	57	GDA1/IO49RSB0	93	GAC1/IO07RSB0
22	GEA1/IO73RSB1	58	GDC0/IO46RSB0	94	GAC0/IO06RSB0
23	GEA0/IO72RSB1	59	GDC1/IO45RSB0	95	GAB1/IO05RSB0
24	VMV1	60	GCC2/IO43RSB0	96	GAB0/IO04RSB0
25	GNDQ	61	GCB2/IO42RSB0	97	GAA1/IO03RSB0
26	GEA2/IO71RSB1	62	GCA0/IO40RSB0	98	GAA0/IO02RSB0
27	FF/GEB2/IO70RSB1	63	GCA1/IO39RSB0	99	IO01RSB0
28	GEC2/IO69RSB1	64	GCC0/IO36RSB0	100	IO00RSB0
29	IO68RSB1	65	GCC1/IO35RSB0		
30	IO67RSB1	66	V _{CC} B0		
31	IO66RSB1	67	GND		
32	IO65RSB1	68	V _{CC}		
33	IO64RSB1	69	IO31RSB0		
34	IO63RSB1	70	GBC2/IO29RSB0		
35	IO62RSB1	71	GBB2/IO27RSB0		
36	IO61RSB1	72	IO26RSB0		

100-Pin VQFP		100-Pin VQFP		100-Pin VQFP	
Pin Number	AGLN125 Function	Pin Number	AGLN125 Function	Pin Number	AGLN125 Function
1	GND	37	V _{CC}	73	GBA2/IO41RSB0
2	GAA2/IO67RSB1	38	GND	74	VMV0
3	IO68RSB1	39	V _{CC} B1	75	GNDQ
4	GAB2/IO69RSB1	40	IO87RSB1	76	GBA1/IO40RSB0
5	IO132RSB1	41	IO84RSB1	77	GBA0/IO39RSB0
6	GAC2/IO131RSB1	42	IO81RSB1	78	GBB1/IO38RSB0
7	IO130RSB1	43	IO75RSB1	79	GBB0/IO37RSB0
8	IO129RSB1	44	GDC2/IO72RSB1	80	GBC1/IO36RSB0
9	GND	45	GDB2/IO71RSB1	81	GBC0/IO35RSB0
10	GFB1/IO124RSB1	46	GDA2/IO70RSB1	82	IO32RSB0
11	GFB0/IO123RSB1	47	TCK	83	IO28RSB0
12	V _{COMPLF}	48	TDI	84	IO25RSB0
13	GFA0/IO122RSB1	49	TMS	85	IO22RSB0
14	V _{CC} PLF	50	VMV1	86	IO19RSB0
15	GFA1/IO121RSB1	51	GND	87	V _{CC} B0
16	GFA2/IO120RSB1	52	V _{PUMP}	88	GND
17	V _{CC}	53	NC	89	V _{CC}
18	V _{CC} B1	54	TDO	90	IO15RSB0
19	GEC0/IO111RSB1	55	TRST	91	IO13RSB0
20	GEB1/IO110RSB1	56	V _{JTAG}	92	IO11RSB0
21	GEB0/IO109RSB1	57	GDA1/IO65RSB0	93	IO09RSB0
22	GEA1/IO108RSB1	58	GDC0/IO62RSB0	94	IO07RSB0
23	GEA0/IO107RSB1	59	GDC1/IO61RSB0	95	GAC1/IO05RSB0
24	VMV1	60	GCC2/IO59RSB0	96	GAC0/IO04RSB0
25	GNDQ	61	GCB2/IO58RSB0	97	GAB1/IO03RSB0
26	GEA2/IO106RSB1	62	GCA0/IO56RSB0	98	GAB0/IO02RSB0
27	FF/GEB2/IO105RSB1	63	GCA1/IO55RSB0	99	GAA1/IO01RSB0
28	GEC2/IO104RSB1	64	GCC0/IO52RSB0	100	GAA0/IO00RSB0
29	IO102RSB1	65	GCC1/IO51RSB0		
30	IO100RSB1	66	V _{CC} B0		
31	IO99RSB1	67	GND		
32	IO97RSB1	68	V _{CC}		
33	IO96RSB1	69	IO47RSB0		
34	IO95RSB1	70	GBC2/IO45RSB0		
35	IO94RSB1	71	GBB2/IO43RSB0		
36	IO93RSB1	72	IO42RSB0		

100-Pin VQFP	
Pin Number	AGLN250 Function
1	GND
2	GAA2/IO67RSB3
3	IO66RSB3
4	GAB2/IO65RSB3
5	IO64RSB3
6	GAC2/IO63RSB3
7	IO62RSB3
8	IO61RSB3
9	GND
10	GFB1/IO60RSB3
11	GFB0/IO59RSB3
12	V _{COMPLF}
13	GFA0/IO57RSB3
14	V _{CCPLF}
15	GFA1/IO58RSB3
16	GFA2/IO56RSB3
17	V _{CC}
18	V _{CCIB3}
19	GFC2/IO55RSB3
20	GEC1/IO54RSB3
21	GEC0/IO53RSB3
22	GEA1/IO52RSB3
23	GEA0/IO51RSB3
24	VMV3
25	GNDQ
26	GEA2/IO50RSB2
27	FF/GEB2/IO49RSB2
28	GEC2/IO48RSB2
29	IO47RSB2
30	IO46RSB2
31	IO45RSB2
32	IO44RSB2
33	IO43RSB2
34	IO42RSB2
35	IO41RSB2
36	IO40RSB2

100-Pin VQFP	
Pin Number	AGLN250 Function
37	V _{CC}
38	GND
39	V _{CCIB2}
40	IO39RSB2
41	IO38RSB2
42	IO37RSB2
43	GDC2/IO36RSB2
44	GDB2/IO35RSB2
45	GDA2/IO34RSB2
46	GNDQ
47	TCK
48	TDI
49	TMS
50	VMV2
51	GND
52	V _{PUMP}
53	NC
54	TDO
55	TRST
56	V _{JTAG}
57	GDA1/IO33RSB1
58	GDC0/IO32RSB1
59	GDC1/IO31RSB1
60	IO30RSB1
61	GCB2/IO29RSB1
62	GCA1/IO27RSB1
63	GCA0/IO28RSB1
64	GCC0/IO26RSB1
65	GCC1/IO25RSB1
66	V _{CCIB1}
67	GND
68	V _{CC}
69	IO24RSB1
70	GBC2/IO23RSB1
71	GBB2/IO22RSB1
72	IO21RSB1

100-Pin VQFP	
Pin Number	AGLN250 Function
73	GBA2/IO20RSB1
74	VMV1
75	GNDQ
76	GBA1/IO19RSB0
77	GBA0/IO18RSB0
78	GBB1/IO17RSB0
79	GBB0/IO16RSB0
80	GBC1/IO15RSB0
81	GBC0/IO14RSB0
82	IO13RSB0
83	IO12RSB0
84	IO11RSB0
85	IO10RSB0
86	IO09RSB0
87	V _{CCIB0}
88	GND
89	V _{CC}
90	IO08RSB0
91	IO07RSB0
92	IO06RSB0
93	GAC1/IO05RSB0
94	GAC0/IO04RSB0
95	GAB1/IO03RSB0
96	GAB0/IO02RSB0
97	GAA1/IO01RSB0
98	GAA0/IO00RSB0
99	GNDQ
100	VMV0

Part Number and Revision Date

Part Number 51700110-003-2

Revised December 2008

List of Changes

The following table lists critical changes that were made in the current version of the chapter.

Previous Version	Changes in Current Version (Advance v0.3)	Page
Advance v0.2 (November 2008)	The "36-Pin UC" pin table is new.	3-2
Advance v0.1 (October 2008)	The "48-Pin QFN" pin diagram was revised.	3-5
	Note 2 for the "48-Pin QFN", "68-Pin QFN", and "100-Pin QFN" pin diagrams was changed to "The die attach paddle of the package is tied to ground (GND)."	3-5, 3-7, 3-10
	The "100-Pin VQFP" pin diagram was revised to move the pin IDs to the upper left corner instead of the upper right corner.	3-11

Actel and the Actel logo are registered trademarks of Actel Corporation.
All other trademarks are the property of their owners.



www.actel.com

Actel is the leader in low-power and mixed-signal FPGAs and offers the most comprehensive portfolio of system and power management solutions. Power Matters. Learn more at www.actel.com.

Actel Corporation

2061 Stierlin Court
Mountain View, CA
94043-4655 USA

Phone 650.318.4200

Fax 650.318.4600

Actel Europe Ltd.

River Court, Meadows Business Park
Station Approach, Blackwater
Camberley Surrey GU17 9AB
United Kingdom

Phone +44 (0) 1276 609 300

Fax +44 (0) 1276 607 540

Actel Japan

EXOS Ebisu Building 4F
1-24-14 Ebisu Shibuya-ku
Tokyo 150 Japan

Phone +81.03.3445.7671

Fax +81.03.3445.7668

<http://jp.actel.com>

Actel Hong Kong

Room 2107, China Resources Building
26 Harbour Road
Wanchai, Hong Kong

Phone +852 2185 6460

Fax +852 2185 6488

www.actel.com.cn

51700110-005-2/12.08

